



SUMMER CITY LONG ISLAND

CHRISTOPHE PILLET

PARALEL

GABRIEL TEIXIDÓ

FUP

FRANCESC RIFÉ

NEW 2020 CATALOGUE

POINT.

Índice
Index

14	SUMMER	04	100 Años <i>100 Years</i>
28	CITY	08	100 Años de Historia <i>100 Years of History</i>
42	LONG ISLAND	10	Mención Honorable <i>Honourable Mention</i>
52	PARALEL	12	Colecciones <i>Collections</i>
76	FUP	82	Diseñadores <i>Designers</i>
		84	Mapa de producto <i>Product Map</i>
		88	Imágenes <i>Pictures</i>
		95	Detalles técnicos <i>Technical Details</i>
		117	Acabados y Mantenimiento <i>Finishes and Maintenance</i>
		127	Telas <i>Fabrics</i>



Jose Juan Pons, director de
diseño y producción.

Jose Juan Pons, design &
production manager.

“Contemplo los 100 años con un poco de nostalgia.”

La celebración del centenario de Point es para mí como celebrar el aniversario de mi vida profesional. Empecé en la empresa con 24 años, y este año cumpla 41 años en la empresa. Puedo decir que “la fábrica”, como la llamamos en casa, es mi vida.

Contemplo los 100 años, con un poco de nostalgia, surgen muchos recuerdos de situaciones pero, sobre todo, de personas que han pasado por la fábrica, personas que consideraban que la empresa era suya, y que dieron todo lo que llevaban dentro en su trabajo. Hemos pasado junto con estas personas momentos duros, y también momentos gozosos. No estaríamos aquí sin su aportación. Creo que el centenario es el momento de rendir homenaje a estas personas.

Pero también tengo en este momento un sentimiento de esperanza en el futuro. En Point hay un equipo joven, preparado, con formación, que va entrando en la dirección de la empresa y que nos asegura un futuro brillante. La vieja guardia nos iremos retirando para dejarles paso.

Finalmente, quiero agradecer a todas las personas que han colaborado con Point en estos años: trabajadores, clientes, proveedores, diseñadores, agentes comerciales. El espíritu de nuestra compañía es hacer amigos con las personas con las que colaboramos. Creo que lo hemos conseguido en gran medida.

Muchas gracias a todos

“I look back over these 100 years with a little nostalgia.”

Point's centenary celebration is like celebrating the anniversary of my professional life. I started out in the company at the age of 24, and this year I'll have been working here for 41 years. I can say that "the factory", as we call it at home, is my life.

I look back over these 100 years with a little nostalgia; there are many memories of situations, but especially of people who have passed through the factory, people who thought of the company as their own and who gave everything they had in their work at the factory. We have gone through some hard times with these people, but also had some joyful moments. We would not be here without their help. I think the centenary is a good time to pay tribute to them.

But I also have a feeling of hope in the future right now. These days we have a young, highly-qualified team at Point that is entering the company's management and ensuring a bright future for us. The older generation will gradually step down and let them take over.

Finally, I want to thank all the people who have collaborated with Point over the years: employees, customers, suppliers, designers, business agents. The spirit of our company is to make friends with the people we collaborate with. I believe we have largely achieved this.

Many thanks to everyone.

Paco Pons, director
de exportación.

Paco Pons,
export manager.



Orgulloso y agradecido.

Estoy orgulloso de la herencia recibida de nuestro abuelo y de nuestro padre; y, por supuesto, muy orgulloso de haber mantenido su legado hasta nuestros días.

Y agradecido a cientos de trabajadores, clientes, proveedores, profesionales del diseño y a todos aquellos que durante estos cien años han colaborado con nuestra familia, haciendo posible que el sueño de nuestros antepasados continúe vivo en el presente.

Proud and grateful.

Proud of everything we inherited from our grandfather and father; very proud to have kept up their legacy to this day.

And grateful to hundreds of employees, customers, suppliers and design professionals, as well as to all those who have collaborated with our family throughout these hundred years, making it possible to keep our ancestors' dream alive in the present.



Vicente Pons,
director comercial.

Vicente Pons,
sales manager.

Diseño e Historia.

El crac del 29, una guerra civil, una guerra mundial, una posguerra, periodo de prosperidad, el final de la dictadura, transición a la democracia, reconversión industrial, crisis financiera, crisis del coronavirus... 100 años.

Cien años de historia conseguidos gracias a la combinación de familia, diseño, esfuerzo y dedicación.

Cien veces gracias a todos los trabajadores que durante cien años nos han acompañado a lo largo de nuestra historia.

Cien veces gracias a las cuatro generaciones de familia que con su comprensión y esfuerzo han hecho posible llegar hasta aquí.

Cien veces gracias a nuestros clientes por ser generosos con nosotros.

Cien veces gracias por poder compartir una experiencia única como es nuestra empresa.

Gracias por haber podido ser partícipe de este proyecto.

Design and History.

The crash of 1929, the civil war, the second world war, the post-war period, a period of prosperity, the end of the dictatorship, the transition to democracy, industrial development, the financial crisis, and now the coronavirus crisis... 100 years.

A hundred years of history accomplished thanks to the combination of family, design, hard work and dedication.

A hundred thank yous to all the workers who have accompanied us throughout our hundred years of history.

A hundred thank yous to the four generations of the family who, with their understanding and effort, have made it possible to reach this point.

A hundred thank yous to our customers for being generous to us.

A hundred thank yous for sharing the unique experience that is our company.

Thank you for being part of this project.



Antonio Pons, miembro
Consejo de Dirección.

Antonio Pons, member
of the board of directors.

Cien años no se cumplen todos los días.

Cien años no se cumplen todos los días y menos en el caso de una empresa familiar como es Point.

Es un orgullo como miembro de la familia Pons celebrar el centenario de nuestra empresa, formar parte del bagaje, de la historia y de este hermoso proyecto que ha sido y que seguirá siendo Point.

Cien años de esfuerzo y trabajo de cada una de las personas que a lo largo de estos cien años han trabajado en nuestra empresa, aportando su profesionalidad y saber hacer. Ellos son parte esencial de nuestra historia, sin ellos, este proyecto no hubiese sido posible.

Mil gracias por formar parte de la familia Point.

Gracias a todos.

It's not every day that one celebrates a hundredth birthday.

It's not every day that one celebrates a hundredth birthday, and less so in the case of a family business like Point.

As a member of the Pons family, I am proud to celebrate our company's centenary and to be part of the baggage and the history of this wonderful project that has been and will continue to be Point.

One hundred years of effort and hard work by each of the people who have worked in our company over the last hundred years, contributing their professionalism and know-how. They are an essential part of our history, without whom this project would not have been possible. Thank you so much for being part of the Point family.

Thank you all

100 Años de Historia 100 Years of History



A Juan Bautista Pons Leyda paseando con su esposa Antonia María García Mulet.



B José Pons Pedro, 1910. La foto data de su etapa en Buenos Aires, donde aprendió a tejer muebles de mimbre.



C Juan Bautista Pons Leyda recibe el Premio de Líder de Exportación en 1975.

D Fábrica en los años 60 en plena producción. En esos años trabajaban en la fábrica unos 300 empleados, lo cual marcaba el ritmo de la población.

La historia de Point es la de un fundador pionero, maestro artesano, que se convirtió en referente empresarial, y la de una familia que, cuatro generaciones después, ha convertido su legado en una marca internacional, sinónimo del mejor diseño, investigación y "savoir faire". La artesanía, la familia y la promoción del talento están en la base de esta historia de éxito.

Point's story is that of a pioneering founder, a master craftsman who became a business leader and the story of a family who, four generations later, have turned his legacy into an international brand, a byword for the finest designs, research and know-how. Craftsmanship, family, and the nurturing of talent are the foundations of this success story.

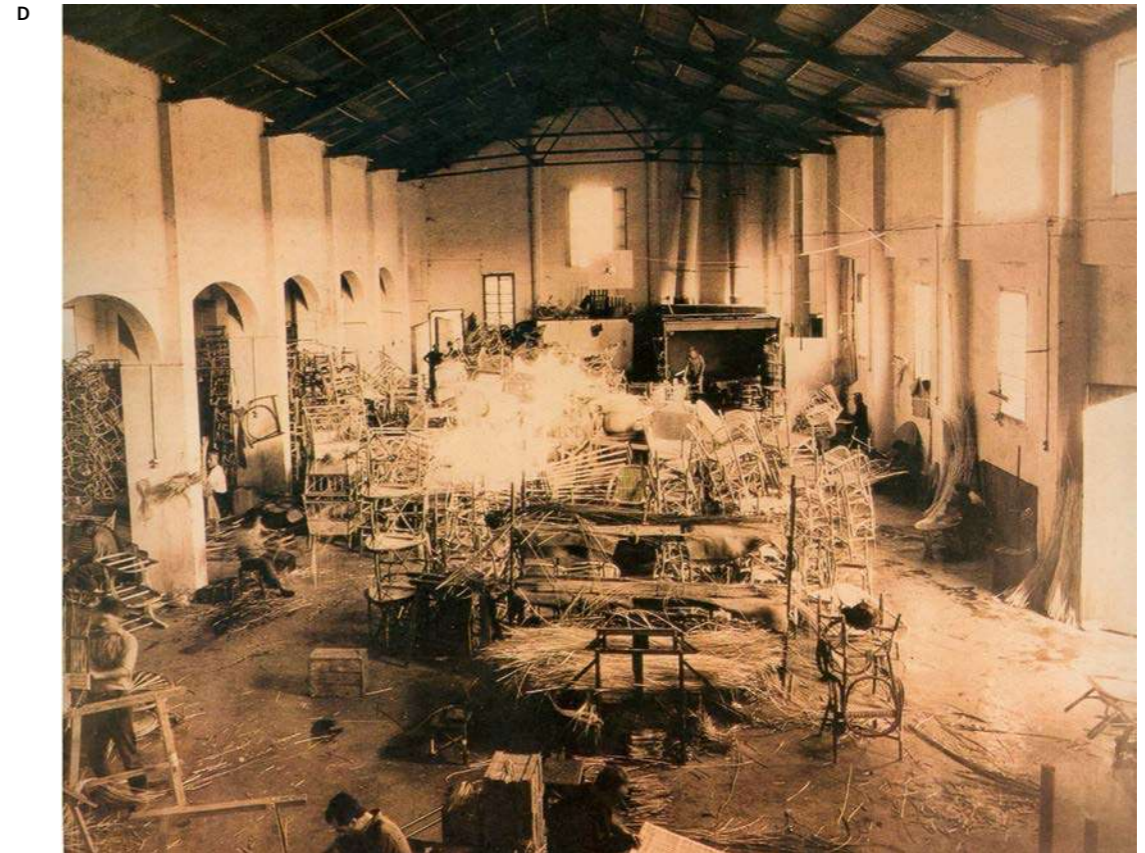

A Juan Bautista Pons Leyda taking a walk with his wife Antonia María García Mulet.

B José Pons Pedro, 1910. The photo dates back to his time in Buenos Aires, where he learned to weave wicker furniture.

C Juan Bautista Pons Leyda receives the Export Leader Award in 1975.

D The factory in the 1960s in full production. At that time there were some 300 employees working at the factory, which set the pace of life in the town.

100 Años de Diseño

El año 2020 es clave para la familia Pons: se cumplen cien años de la fundación de la empresa, que pasó de ser un pequeño taller de trenzado de mimbre a una de las industrias más importantes de la Marina Alta (en Alicante) y un referente internacional. La cuarta generación ya está preparada para continuar impulsando el poderoso ADN de la marca y al equipo se suma Mario Ruiz, Premio Nacional de Diseño en 2016.

100 Years of Design

2020 is a critical year for the Pons family: it marks the centenary of the founding of the company, which has grown from a small wicker weaving workshop to one of the biggest industries in the Marina Alta area (Alicante) and a leading international name. The fourth generation is set to continue driving forward the brand's powerful DNA and the team is joined by Mario Ruiz, 2016 National Design Award winner.

Mención Honorable Honourable Mention



E



G



H



F

E Los hermanos Pons con Su Majestad el Rey Don Felipe VI.
F - G Hermanos Pons.
H Familia Pons al completo junto con algunos de los colaboradores de la marca.

E The Pons brothers with His Majesty King Felipe VI.
F - G The Pons brothers.
H The entire Pons Family alongside some of the brand's collaborators.

POINT, Premio Nacional de Diseño 2019
El Ministerio de Ciencia, Innovación y Universidades concedió a POINT el Premio Nacional de Diseño 2019 en la modalidad 'Empresa'. Es el más alto galardón que se otorga en nuestro país a las empresas y profesionales que han destacado por su trayectoria ejemplar en el campo del diseño y de la innovación.

POINT, 2019 Spanish National Design Award
The Spanish Ministry of Science, Innovation and Universities has awarded us the 2019 National Design Award in the 'Business' category. It is the highest accolade given in our country to companies and professionals that stand out for their exemplary track record in the field of design and innovation.



I

I Vicente Pons, director comercial de POINT, recogiendo el Premio Nacional de Diseño categoría 'Empresa' 2019 de mano de Su Majestad la Reina Doña Letizia.
Vicente Pons, POINT's sales manager, collecting the 2019 National Design Award in the 'Business' category from Her Majesty Queen Letizia.



SUMMER

CHRISTOPHE PILLET

Es una revisión de la silla tradicional: universal, simple, funcional y atemporal ahora vista desde el refinamiento, la precisión técnica y la sensualidad.

«El efecto decorativo se produce aquí por la textura del trenzado. Por lo tanto, hay algo muy elaborado (hecho a mano), de diseño muy fuerte y muy simple». Explica el diseñador. Realizada en aluminio combinado con cuerda o Shintotex®. Está disponible en dos colores. «Estamos ante un objeto casi indefinido, clásico, universal, que rediseñamos muy ligeramente para darle una nueva modernidad».

This is a new take on the traditional chair: universal, simple, functional and timeless, but now given a touch of refinement, technical precision and sensuality.

"The decorative effect is produced here by the texture of the weave. It therefore has something very elaborate (handmade), with a very strong, very simple design," explains the designer. Made from aluminium combined with rope or Shintotex®. Available in two colours.

"This is an almost indefinite, classic, universal object, which we redesigned very slightly to give it a new touch of modernity".

CITY

CHRISTOPHE PILLET

«Con esta colección trato de describir, de manera contemporánea, un arte de vivir mediterráneo, que no tiene que ver con el tiempo. Es un universo donde el sol y la tierra se unen». Este conjunto crea una composición de gran comodidad y armonía.

Las tres piezas de la colección –un sillón, un sofá doble y uno triple–, destilan clasicismo y elegancia y sus cojines pueden ser personalizados tanto en estampados como en colores.

"This collection is my contemporary take on the art of Mediterranean living, which is unconnected to time. It is a universe where the Sun and the Earth meet". These pieces create a composition of great comfort and harmony. The three pieces in the collection –an armchair, a double sofa and a triple sofa– exude classicism and elegance, and their cushions can be customised in terms of both prints and colours.

LONG ISLAND

CHRISTOPHE PILLET

«Mi objetivo con esta colección ha sido que fuera tan deseable, con un diseño tan detallista y tan bien terminada como un mueble de interior». Explica Pillet y añade, «busqué crear la sensación de que estas piezas siempre han existido». Como un moderno clásico. Formas rectas y líneas finas definen la silueta de esta colección modular de sofás de exterior. Eminentemente versátil, las piezas que la componen pueden ser un sillón, un sofá o una chaise longue adaptándose a cada espacio.

"My goal with this collection was to make it as desirable and as well finished as a piece of indoor furniture, with a similarly detailed design," Pillet explains, adding "I sought to create the feeling that these pieces have always existed". Like a modern classic. Straight shapes and slim lines define the silhouette of this modular collection of outdoor sofas. Eminently versatile, the pieces that make up the collection include an armchair, a sofa and a chaise longue, which adapt to fit each space.

PARALEL

GABRIEL TEIXIDÓ

Diseñada a base de madera de teca de Indonesia –de bosques de tala controlada– y cuerda, esta colección está formada por un conjunto de quince piezas que incluyen sillas, sillones, butacas y mesas de estética contemporánea y gran confort, cuya parte trasera le otorga su punto característico y diferencial.

Como explica Teixidó, «se trata de una colección serena, que llega para quedarse, cuyo elemento característico, la madera, es un elemento vivo que conecta bien con las personas y aporta calidez».

Designed by Gabriel Teixidó and made from Indonesian teak wood –sourced from carefully managed forests– and rope, this collection consists of a set of fifteen pieces including chairs, armchairs, sofas and tables in a contemporary style that offer great comfort. They are characterised by their back, their most distinguishing feature. As Teixidó explains, "this is a serene collection, which is here to stay, whose characteristic element, wood, is a living element that connects well with people and gives it warmth".

FUP

FRANCESC RIFÉ

Estas piezas siguen el principio geométrico de la filosofía de trabajo de Francesc Rifé y toman como eje la simplicidad del círculo y el equilibrio de la materia. El voluminoso cuerpo tapizado contrasta con una estrecha base de madera de teca, resistente y de la más alta calidad. Un diseño que encontramos disponible en dos tamaños y alturas, que funciona bien tanto en conjunto como en solitario.

These pieces follow the geometric principle of Francesc Rifé's work philosophy and are based on the simplicity of the circle and the balance of matter. The bulk of the upholstered body contrasts with a narrow base made from hardwearing teak wood of the highest quality. This design is available in two sizes and heights, which work well either together or alone.

SUMMER

CHRISTOPHE PILLET

"This is a new take on the traditional chair: universal, simple, functional and timeless, but now given a touch of refinement, technical precision and sensuality."















CITY

CHRISTOPHE PILLET

"This collection is my contemporary take on the art of Mediterranean living, which is unconnected to time. It is a universe where the Sun and the Earth meet".















LONG ISLAND

CHRISTOPHE PILLET

"My goal with this collection was to make it as desirable and as well finished as a piece of indoor furniture, with a similarly detailed design".











PARALEL

GABRIEL TEIXIDÓ

"This is a serene collection, which is here to stay, whose characteristic element, wood, is a living element that connects well with people and gives it warmth".

























FUP

FRANCESC RIFÉ

These pieces follow the geometric principle of Francesc Rifé's work philosophy and are based on the simplicity of the circle and the balance of matter.

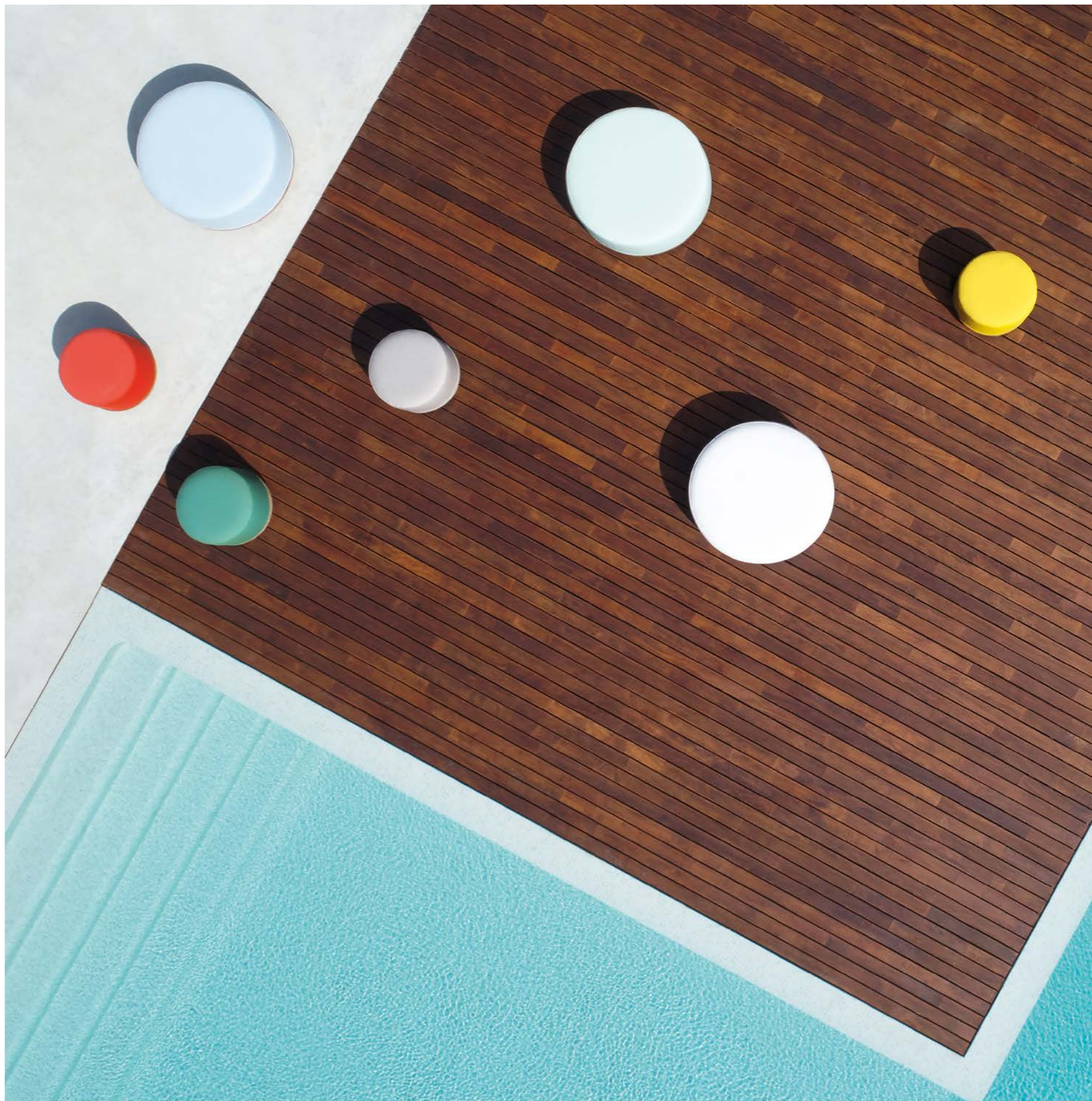







Francesc Rifé



Christophe Pillet



Gabriel Teixidó

CHRISTOPHE PILLET

—
SUMMER

p.14

CITY

p.28

LONG ISLAND

p.42

GABRIEL TEIXIDÓ

—
PARALEL

p.52

FRANCESC RIFÉ

—
FUP

p.76

Mapa de producto Product map

Silla Side Chair



Ref. 77901
Summer
P. 14 · T. 96



Ref. 77601
Paralel
P. 52 · T. 110

Sillón Comedor Armchair



Ref. 77906
Summer
P. 14 · T. 96



Ref. 77606
Paralel
P. 52 · T. 110

Taburetes Stools



Ref. 77652
Paralel
P. 52 · T. 110

Sillones Club Club Small Lounge Chairs



Ref. 77605
Paralel
P. 52 · T. 110

Sillones Lounge Chairs



Ref. 78345
City
P. 28 · T. 99



Ref. 77845
Long Island
P. 42 · T. 101

Sofas Sofas



Ref. 78347
City
Sofá 2 | Sofa 2
P. 28 · T. 99



Ref. 78349
City
Sofá 3 | Sofa 3
P. 28 · T. 99



Ref. 77847
Long Island
Sofá 2 | Sofa 2
P. 42 · T. 101



Ref. 77849
Long Island
Sofá 3 | Sofa 3
P. 42 · T. 101



Ref. 77647
Paralel
Sofá 2 | Sofa 2
P. 52 · T. 111



Ref. 77649
Paralel
Sofá 3 | Sofa 3
P. 52 · T. 111

Sofas Modulares Modular Sofas



Ref. 77846
Long Island
Sofá 2 Brazo Izq.
Sofa 2 Left Arm
P. 42 · T. 102



Ref. 77844
Long Island
Sofá 2 Brazo Dcho.
Sofa 2 Right Arm
P. 42 · T. 102



Ref. 77850
Long Island
Sofá 2 Sin Brazos
Sofa 2 Without Arms
P. 42 · T. 102



Ref. 77843
Long Island
Sofá 3 Brazo Izq.
Sofa 3 Left Arm
P. 42 · T. 103



Ref. 77842
Long Island
Sofá 3 Brazo Dcho.
Sofa 3 Right Arm
P. 42 · T. 103



Ref. 77851
Long Island
Sofá 3 Sin Brazos
Sofa 3 Without Arms
P. 42 · T. 104



Ref. 77645
Paralel
P. 52 · T. 111

Chaise Longue
Chaise Longue



Ref. 77896
Long Island
P. 42 · T. 105



Ref. 77895
Long Island
P. 42 · T. 105

Mesas
Tables



Ref. 78354
City
Mesa Centro
Coffee Table
P. 28 · T. 100



Ref. 77853
Long Island
Mesa Centro
Coffee Table
P. 42 · T. 106

Rinconera
Corner



Ref. 77844
Long Island
P. 42 · T. 104



Ref. 77854
Long Island
Mesa Centro
Coffee Table
P. 42 · T. 106



Ref. 77654
Paralel
Mesa Centro
Coffee Table
P. 52 · T. 112

Puf
Ottoman



Ref. 77751
Fup
P. 76 · T. 115



Ref. 77752
Fup
P. 76 · T. 115



Ref. 77910
Summer
Mesa Comedor
Dining Table
P. 14 · T. 97



Ref. 77610
Paralel
Mesa Comedor
Dining Table
P. 52 · T. 113

Mesas
Tables



Ref. 78357
City
Mesa Rincón
Side Table
P. 28 · T. 100



Ref. 78356
City
Mesa Rincón
Side Table
P. 28 · T. 100



Ref. 77611
Paralel
Mesa Comedor
Dining Table
P. 52 · T. 113



Ref. 77908
Summer
Mesa Comedor
Dining Table
P. 14 · T. 97



Ref. 77856
Long Island
Mesa Rincón
Side Table
P. 42 · T. 106



Ref. 77656
Paralel
Mesa Rincón
Side Table
P. 52 · T. 112



Ref. 77909
Summer
Mesa Comedor
Dining Table
P. 14 · T. 98



Ref. 77609
Paralel
Mesa Comedor
Dining Table
P. 52 · T. 114



Ref. 77615
Paralel
Mesa Club
Coffee Table
P. 52 · T. 112



Ref. 78353
City
Mesa Centro
Coffee Table
P. 28 · T. 100



Ref. 77608
Paralel
Mesa Comedor
Dining Table
P. 52 · T. 114



Summer p.15

Ref. 77901 Silla | Side chair C/56 Cuerda grafito / Graphite rope

Ref. 77901 Silla | Side chair C/56 Fibra sintética marrón castaño / Chestnut brown synthetic fibre

Ref. 77906 Sillón comedor | Armchair C/34 Cuerda beige / Beige rope

Ref. 77906 Sillón comedor | Armchair C/34 Fibra sintética gris plata / Silver grey synthetic fibre

Ref. 77901 Silla | Side chair C/56 Fibra sintética gris oscuro / Dark grey synthetic fibre

Ref. 77901 Silla | Side chair C/34 Cuerda beige / Beige rope

Ref. 77901 Silla | Side chair C/34 Fibra sintética blanco / White synthetic fibre

Ref. 77906 Sillón comedor | Armchair C/56 Fibra sintética marrón castaño / Chestnut brown synthetic fibre

Ref. 77906 Sillón comedor | Armchair C/56 Cuerda gris perlado / Pearl grey rope

Ref. 77909 Mesa comedor rectangular 240 x 100 x 74 cm | Rectangular dining table 94.5 x 39.4 x 29.1 in C/34 Tapa / Top 81

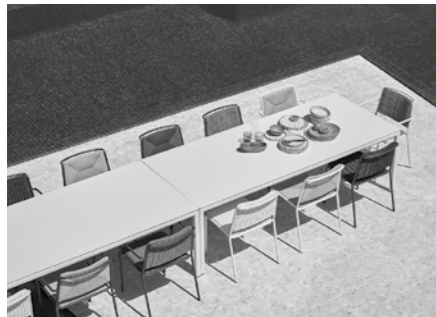

Summer p.16

Ref. 77906 Sillón comedor | Armchair C/56 Fibra sintética gris oscuro / Dark grey synthetic fibre

Ref. 77901 Silla | Side chair C/56 Cuerda gris perlado / Pearl grey rope

Ref. 77901 Silla | Side chair C/56 Cuerda grafito / Graphite rope

Ref. 77901 Silla | Side chair C/56 Fibra sintética marrón castaño / Chestnut brown synthetic fibre

Ref. 77906 Sillón comedor | Armchair C/34 Cuerda beige / Beige rope

Ref. 77906 Sillón comedor | Armchair C/34 Fibra sintética gris plata / Silver grey synthetic fibre

Ref. 77901 Silla | Side chair C/56 Fibra sintética gris oscuro / Dark grey synthetic fibre

Ref. 77901 Silla | Side chair C/34 Cuerda beige / Beige rope

Ref. 77901 Silla | Side chair C/34 Fibra sintética Blanco / White synthetic fibre

Ref. 77906 Sillón comedor | Armchair C/56 Fibra sintética marrón castaño / Chestnut brown synthetic fibre

Ref. 77906 Sillón comedor | Armchair C/56 Cuerda gris perlado / Pearl grey rope

Ref. 77901 Silla | Side chair C/34 Fibra sintética blanco / White synthetic fibre

Ref. 77909 Mesa comedor rectangular 240 x 100 x 74 cm | Rectangular dining table 94.5 x 39.4 x 29.1 in C/34 Tapa porcelánico blanco natural 81 / Porcelain top natural white 81



Summer p.18

Ref. 77901 Silla | Side chair C/56 Cuerda Grafito / Graphite rope

Ref. 77906 Sillón comedor | Armchair C/56 Cuerda gris perlado / Pearl grey rope

Ref. 77908 Mesa comedor rectangular 180 x 100 x 74 cm | Rectangular dining table 70.9 x 39.4 x 29.1 in C/56 Tapa porcelánico gris lava 82 / Porcelain top light grey 82



Summer p.20

Ref. 77906 Sillón comedor | Armchair C/56 Cuerda gris perlado / Pearl grey rope



Summer p.21

Ref. 77901 Silla | Side chair C/56 Cuerda grafito / Graphite rope

Ref. 77906 Sillón comedor | Armchair C/56 Cuerda gris perlado / Pearl grey rope

Ref. 77908 Mesa comedor rectangular 180 x 100 x 74 cm | Rectangular dining table 70.9 x 39.4 x 29.1 in C/56 Tapa porcelánico gris lava 82 / Porcelain top lava grey 82



Summer p.22

Ref. 77906 Sillón comedor | Armchair C/34 Cuerda gris perlado / Pearl grey rope

Ref. 77908 Mesa comedor rectangular 180 x 100 x 74 cm | Rectangular dining table 70.9 x 39.4 x 29.1 in C/34 Tapa porcelánico gris claro 80 / Porcelain top light grey 80



Summer p.24

Ref. 77901 Silla | Side chair C/34 Cuerda beige / Beige rope



Summer p.25

Ref. 77906 Sillón comedor | Armchair C/34 Cuerda gris perlado / Pearl grey rope

Ref. 77908 Mesa comedor rectangular 180 x 100 x 74 cm | Rectangular dining table 70.9 x 39.4 x 29.1 in C/34 Tapa porcelánico gris claro 80 / Porcelain top light grey 80



Summer p.26

Ref. 77901 Silla | Side chair C/56 Fibra sintética gris oscuro / Dark grey synthetic fibre

Ref. 77906 Sillón comedor | Armchair C/56 Fibra sintética gris oscuro / Dark grey synthetic fibre

Ref. 77909 Mesa comedor rectangular 240 x 100 x 74 cm | Rectangular dining table 94.5 x 39.4 x 29.1 in C/56 Tapa porcelánico negro 82 / Porcelain top black 82



City p.29

Ref. 78349 Sofá 3 | Sofa 3 C/56 T/1220 | 2 x Cuadrante / Cushion T / F 1072 | 2 x Cuadrante / Cushion T / F 1227

Ref. 78347 Sofá 2 | Sofa 2 C/56 T / F 1220 | 2 x Cuadrante / Cushion T / F 1072 | 2 x Cuadrante / Cushion T / F 1227

Ref. 78345 Sillón | Lounge chair C/34 T / F 1227 | 1 x Cuadrante / Cushion T / F 1220

Ref. 78353 Mesa centro cuadrada 100 x 100 x 20,2 cm | Square coffee table 39.4 x 39.4 x 7.9 in C/34 Tapa porcelánico blanco natural 81 / Porcelain top natural white 81

Ref. 78356 Mesa rincón cuadrada 56 x 56 x 52,2 cm | Square side table 22 x 22 x 20.5 in C/34 Tapa porcelánico blanco natural 81 / Porcelain top natural white 81



City p.30

Ref. 78349 Sofá 3 | Sofa 3 C/56 T / F 1220 | 1 x Cuadrante / Cushion T / F 1072 | 1 x Cuadrante / Cushion T / F 1227

Ref. 78345 Sillón | Lounge chair C/34 T / F 1227 | 1 x Cuadrante / Cushion T / F 1220

Ref. 78353 Mesa centro cuadrada 100 x 100 x 20,2 cm | Square coffee table 39.4 x 39.4 x 7.9 in C/34 Tapa porcelánico blanco natural 81 / Porcelain top natural white 81



City p.32

Ref. 78349 Sofá 3 | Sofa 3 C/34 T / F 1240 | 2 x Cuadrante / Cushion T / F 1071 | 2 x Cuadrante / Cushion T / F 1011

Ref. 78354 Mesa centro rectangular 120 x 70 x 20,2 cm | Rectangular coffee table 47.2 x 27.5 x 7.9 in C/34 Tapa porcelánico blanco natural 81 / Porcelain top natural white 81

Ref. 78356 Mesa rincón cuadrada 56 x 56 x 52,2 cm | Square side table 22 x 22 x 20.5 in C/34 Tapa porcelánico blanco natural 81 / Porcelain top natural white 81



City p.34

Ref. 78349 Sofá 3 | Sofa 3 C/34 T / F 1240 | 2 x Cuadrante / Cushion T / F 1071 | 2 x Cuadrante / Cushion T / F 1011

Ref. 78354 Mesa centro rectangular 120 x 70 x 20,2 cm | Rectangular coffee table 47.2 x 27.5 x 7.9 in C/34 Tapa porcelánico blanco natural 81 / Porcelain top natural white 81



City p.36

Ref. 78345 Sillón | Lounge chair C/34 T / F 1238 | 1 x Cuadrante / Cushion T / F 1080

Ref. 78357 Mesa rincón redonda Ø 70 x 52,2 cm / Round side table Ø 27.5 x 20.5 in C/34 Tapa porcelánico blanco natural 81 / Porcelain top natural white 81



City p.37

Ref. 78357 Mesa rincón redonda Ø 70 x 52,2 cm / Round side table Ø 27.5 x 20.5 in C/34 Tapa porcelánico blanco natural 81 / Porcelain top natural white 81



City p.38

Ref. 78345 Sillón | Lounge chair C/56 T / F 1041 | 1 x Cuadrante / Cushion T / F 1233

Ref. 78356 Mesa rincón cuadrada 56 x 56 x 52,2 cm | Square side table 22 x 22 x 20.5 in C/56 Tapa porcelánico gris lava 82 / Porcelain top lava grey 82



City p.40

Ref. 78345 Sillón | Lounge chair C/56 T / F 1041 | 1 x Cuadrante / Cushion T / F 1233

Ref. 78356 Mesa rincón cuadrada 56 x 56 x 52,2 cm | Square side table 22 x 22 x 20.5 in C/56 Tapa porcelánico gris lava 82 / Porcelain top lava grey 82



City p.41

Ref. 78345 Sillón | Lounge chair C/56 T / F 1041 | 1 x Cuadrante / Cushion T / F 1233

Ref. 78356 Mesa rincón cuadrada 70 x 70 x 53,2 cm | Square side table 27.5 x 27.5 x 20.9 in | Square side table C/56 Tapa porcelánico gris lava 82 / Porcelain top lava grey 82



Long Island p.43

Ref. 77843 Sofá 3 Mod. izquierdo | Mod. Sofa 3 left T / F 1080 | 2 x Cuadrante / Cushion T / F 1072 | 2 x Cuadrante / Cushion T / F 1226 | 1 x Cuadrante / Cushion T / F 1227

Ref. 77896 Chaise longue derecho | Chaise longue right T / F 1080 | 1 x Cuadrante / Cushion T / F 1072 | 1 x Cuadrante / Cushion T / F 1226 | 1 x Cuadrante / Cushion T / F 1227

Ref. 77854 Mesa centro rectangular 120 x 70 x 37,2 cm | Rectangular coffee table 47.2 x 27.5 in C/56 Tapa porcelánico gris lava 82 / Porcelain top lava grey 82



Long Island p.44

Ref. 77843 Sofá 3 Mod. izquierdo | Mod. Sofa 3 left T / F 1080 | 2 x Cuadrante / Cushion T / F 1072 | 2 x Cuadrante / Cushion T / F 1226 | 1 x Cuadrante / Cushion T / F 1227

Ref. 77896 Chaise longue derecho | Chaise longue right T / F 1080 | 1 x Cuadrante / Cushion T / F 1072 | 1 x Cuadrante / Cushion T / F 1226 | 1 x Cuadrante / Cushion T / F 1227

Ref. 77854 Mesa centro rectangular 120 x 70 x 37,2 cm | Rectangular coffee table 47.2 x 27.5 in C/56 Tapa porcelánico gris lava 82 / Porcelain top lava grey 82



Long Island p.46

Ref. 77843 Sofá 3 Mod. izquierdo | Mod. Sofa 3 left T / F 1080 | 2 x Cuadrante / Cushion T / F 1231 | 2 x Cuadrante / Cushion T / F 1204 | 2 x Cuadrante / Cushion T / F 1247

Ref. 77842 Sofá 3 Mod. derecho | Mod. Sofa 3 right T / F 1080 | 1 x Cuadrante / Cushion T / F 1231 | 1 x Cuadrante / Cushion T / F 1204 | 1 x Cuadrante / Cushion T / F 1247

Ref. 77845 Sillón | Lounge chair T / F 1080

Ref. 77854 Mesa centro rectangular 120 x 70 x 37,2 cm | Rectangular coffee table 47.2 x 27.5 in C/56 Tapa porcelánico blanco natural 81 / Porcelain top natural white 81

Ref. 77856 Mesa rincón cuadrada 70 x 70 x 53,2 cm | Square side table 27.5 x 27.5 x 20.9 in C/56 Tapa porcelánico blanco natural 81 / Porcelain top natural white 81



Long Island p.48

Ref. 77843 Sofá 3 Mod. izquierdo | Mod. Sofa 3 left T/1080 | 1 x Cuadrante / Cushion T / F 1231 | 1 x Cuadrante / Cushion T / F 1204 | 1 x Cuadrante / Cushion T / F 1247

Ref. 77854 Mesa centro rectangular 120 x 70 x 37,2 cm | Rectangular coffee table 47.2 x 27.5 in x 14.6 in C/56 Tapa porcelánico blanco natural 81 / Porcelain top natural white 81

Ref. 77856 Mesa rincón cuadrada 70 x 70 x 53,2 cm | Square side table 27.5 x 27.5 x 20.9 in C/56 Tapa porcelánico blanco natural 81 / Porcelain top natural white 81



Long Island p.50

Ref. 77895 Chaise longue izquierdo | Chaise longue left T / F 1080 | 1 x Cuadrante / Cushion T / F 1080 | 1 x Cuadrante / Cushion T / F 1235

Ref. 77896 Chaise longue derecho | Chaise longue right T / F 1080 | 1 x Cuadrante / Cushion T / F 1080 | 1 x Cuadrante / Cushion T / F 1235

Ref. 77856 Mesa rincón 70 x 70 x 53,2 cm | Square side table 27.5 x 27.5 x 20.9 in C/56 Tapa porcelánico blanco natural 81 / Porcelain top natural white 81



Long Island p.51

Ref. 77895 Chaise longue izquierdo | Chaise longue left T / F 1080 | 1 x Cuadrante / Cushion T / F 1080 | 1 x Cuadrante / Cushion T / F 1235

Ref. 77856 Mesa rincón 70 x 70 x 53,2 cm | Square side table 27.5 x 27.5 x 20.9 in C/56 Tapa porcelánico blanco natural 81 / Porcelain top natural white 81



Paralel p.53

Ref. 77601 Silla | Side chair

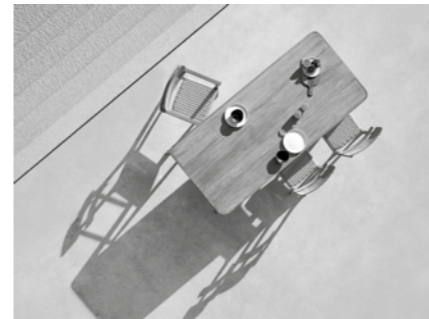

Paralel p.54

Ref. 77608 Mesa comedor rectangular 226 x 109 x 72,5 cm Rectangular dining table 89 x 42.9 x 28.5 in

Ref. 77601 Silla | Side chair

Ref. 77606 Sillón comedor | Armchair



Paralel p.56

Ref. 77647 Sofá 2 | Sofa 2 Tela | Fabric 1221 2x Cuadrantes | Cushions Tela | Fabric 1214 2x Cuadrantes | Cushions Tela | Fabric 1235

Ref. 77615 Mesa club Ø 77,5 x 55,5 cm | Round coffee table Ø 30,5 x 21.9 in

Ref. 77654 Mesa centro rectangular 141 x 72 x 40 cm | Rectangular coffee table 55.5 x 28.3 x 15.7 in

Ref. 77605 Sillón club | Club small lounge chair



Paralel p.58

Ref. 77615 Mesa club Ø 77,5 x 55,5 cm | Round coffee table Ø 30,5 x 21.9 in



Paralel p.59

Ref. 77654 Mesa centro rectangular 141 x 72 x 40 cm | Rectangular coffee table 55.5 x 28.3 x 15.7 in



Paralel p.60

Ref. 77608 Mesa comedor rectangular 226 x 109 x 72,5 cm Rectangular dining table 89 x 42.9 x 28.5 in

Ref. 77601 Silla | Side chair

Ref. 77606 Sillón comedor | Armchair



Paralel p.62

Ref. 77608 Mesa comedor rectangular 226 x 109 x 72,5 cm Rectangular dining table 89 x 42.9 x 28.5 in

Ref. 77601 Silla | Side chair



Paralel p.63

Ref. 77652 Taburete | Stool



Paralel p.64

Ref. 77647 Sofá 2 | Sofa 2 T / F 1220 1 x Cuadrante | Cushion T / F 1207 1 x Cuadrante | Cushion T / F 1245

Mist
Ref. 76481 Ivory 36
Ref. 76482 Ivory 36

Ref. 77656 Mesa rincón | Square side table

Ref. 77654 Mesa centro rectangular 141 x 72 x 40 cm | Rectangular coffee table 55.5 x 28.3 x 15.7 in

Ref. 77645 Sillón | Lounge chair T / F 1220 1 x Cuadrante | Cushion T / F 1245



Paralel p.66

Ref. 77610 Mesa comedor cuadrada 107 x 107 x 72,5 cm | Square dining table 42.1 x 42.1 x 28.5 in

Ref. 77601 Silla | Side chair

**Paralel p.67**

Ref. 77611
Mesa comedor redonda Ø 130,5 x 72,5 cm | Round dining table Ø 51.4 x 28.5 in

Ref. 77606
Sillón comedor | Armchair T / F 1243

**Paralel p.68**

Ref. 77615
Mesa club Ø77,5 x 55,5 cm | Round coffee table Ø 30.5 x 21.9 in

Ref. 77605
Sillón club | Club small lounge chair

**Paralel p.70**

Ref. 77649
Sofá 3 | Sofa 3 T / F 1220 | 2 x Cuadrantes | Cushions T / F 1239 | 2 x Cuadrantes | Cushions T / F 1069

Ref. 77647
Sofá 2 | Sofa 2 T / F 1220 | 2 x Cuadrantes | Cushions T / F 1239 | 2 x Cuadrantes | Cushions T / F 1069

Ref. 77656
Mesa rincón 74 x 74 x 56 cm | Square side table 29.1 x 29.1 x 22 in

Ref. 77654
Mesa centro rectangular 141 x 72 x 40 cm | Rectangular coffee table 55.5 x 28.3 x 15.7 in

Ref. 77615
Mesa club Ø77,5 x 55,5 cm | Round coffee table Ø 30.5 x 21.9 in

Ref. 77645
Sillón | Lounge chair T / F 1220
1 x Cuadrante | Cushion T / F 1239

**Paralel p.72**

Ref. 77645
Sillón | Lounge chair T / F 1220

**Paralel p.73**

Ref. 77605
Sillón club | Club small lounge chair

**Paralel p.74**

Ref. 77649
Sofá 3 | Sofa 3 T / F 1241
2 x Cuadrantes | Cushions T / F 1227
2 x Cuadrantes | Cushions T / F 1226

Ref. 77656
Mesa rincón 74 x 74 x 56 cm | Square side table 29.1 x 29.1 x 22 in

Ref. 77654
Mesa centro rectangular 141 x 72 x 40 cm | Rectangular coffee table 55.5 x 28.3 x 15.7 in

Ref. 77645
Sillón | Lounge chair T / F 1241
1 x Cuadrante | Cushion T / F 1227

Ref. 77652
Taburete | Stool

Fup
Ref. 77752 Puf | Ottoman T / F 1220

Ref. 77751 Puf | Ottoman T / F 1217

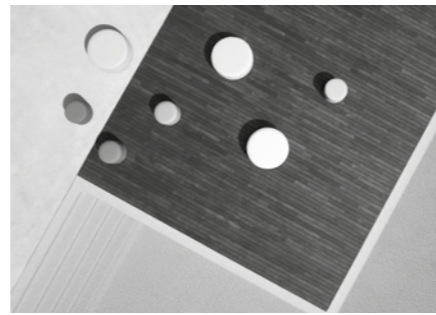
**Fup p.77**

Ref. 77752 Puf | Ottoman T / F 1220

Ref. 77751 Puf | Ottoman T / F 1216

Ref. 77752 Puf | Ottoman T / F 1082

Ref. 77751 Puf | Ottoman T / F 1217

Ref. 77752 Puf | Ottoman T / F 1084

Ref. 77751 Puf | Ottoman T / F 1214

Ref. 77751 Puf | Ottoman T / F 1239

**Fup p.78**

Ref. 77752 Puf | Ottoman T / F 1220

Ref. 77751 Puf | Ottoman T / F 1217

**Fup p.79**

Ref. 77752 Puf | Ottoman T / F 1220

Ref. 77751 Puf | Ottoman T / F 1214

Ref. 77751 Puf | Ottoman T / F 1239

**Fup p.80**

Ref. 77752 Puf – Ottoman T / F 1220

Ref. 77751 Puf – Ottoman T / F 1216

Ref. 77752 Puf – Ottoman T / F 1082

Ref. 77751 Puf – Ottoman T / F1217

Ref. 77752 Puf – Ottoman T / F 1084

Ref. 77751 Puf – Ottoman T / F 1214

Ref. 77751 Puf – Ottoman T / F 1239

DETALLES
TÉCNICOS

TECHNICAL
DETAILS

SILLA | SIDE CHAIR

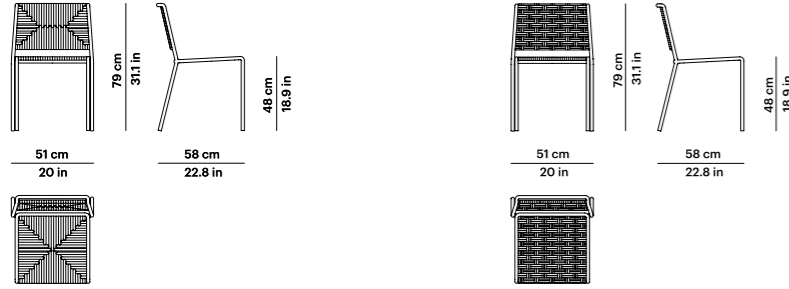

Ref. 77901

Peso Weight

11 Kg 24.2 lb (1 pc)
36,4 Kg 80.2 lb (4 pcs)
0,34 m³ (1pc)
0,38 m³ (4pcs)



Apilable
Stackable

SILLÓN COMEDOR | ARMCHAIR

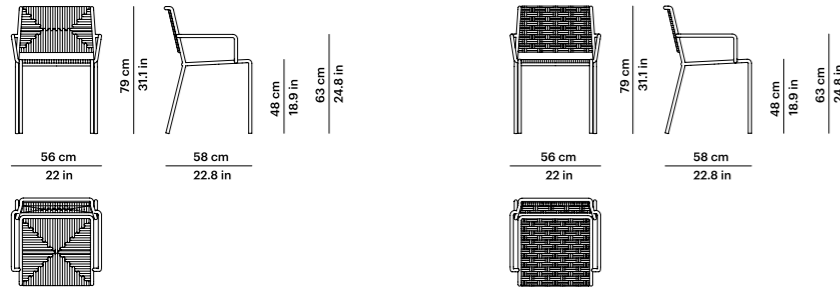

Ref. 77906

Peso Weight

11,4 Kg 25.1 lb (1 pc)
38 Kg 83.8 lb (4 pcs)
0,32 m³ (1pc)
0,36 m³ (4pcs)



Apilable
Stackable

Materiales y acabados Materials and finishes

Estructura Frame
Aluminio pintado en polvo
Powder coated aluminium



Crema 34
Cream 34



Gris metalizado 56
Gunmetal grey 56

Trenzado Weave
Cuerda Ø4mm
Rope Ø4mm



Beige Beige



Gris perlado
Pearl grey



Grafito Graphite

Trenzado Weave
Shintotex®
Shintotex®

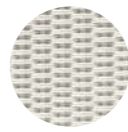

Blanco
White

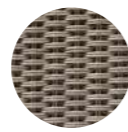

Gris plata
Silver grey



Marrón castaño
Chestnut brown

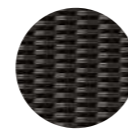

Gris oscuro
Dark grey

MESA COMEDOR CUADRADA 100 x 100 x 74 cm SQUARE DINING TABLE 39.4 x 39.4 x 29.1 in

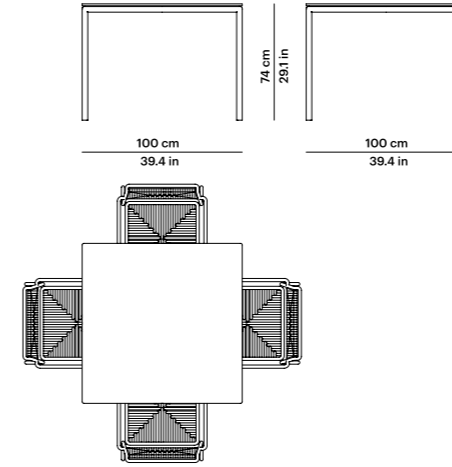

Ref. 77910

Peso Weight

52 Kg con tapa porcelánico
114.6 lb with porcelain top
41 Kg con tapa compacto
90.4 lb with HPL top
1,03 m³

m³



Patas regulables
Adjustable legs

MESA COMEDOR RECTANGULAR 180 x 100 x 74 cm RECTANGULAR DINING TABLE 70.9 x 39.4 x 29.1 in

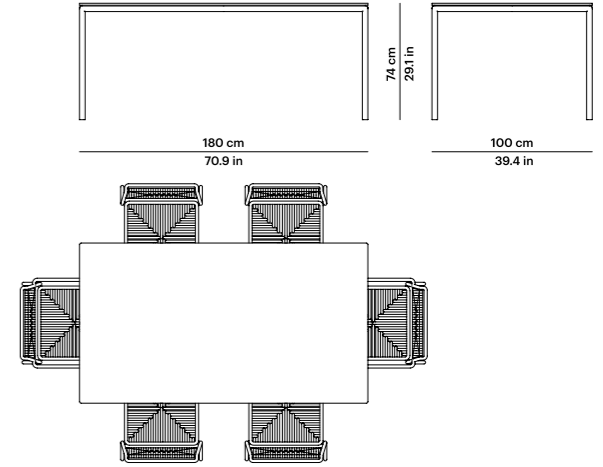

Ref. 77908

Peso Weight

111,7 Kg con tapa porcelánico
246.4 lb with porcelain top
92 Kg con tapa compacto
202.8 lb with HPL top
1,78 m³

m³



Patas regulables
Adjustable legs

Materiales y acabados Materials and finishes

Estructura Frame
Aluminio pintado en polvo
Powder coated aluminium



Crema 34
Cream 34



Gris metalizado 56
Gunmetal grey 56

Tapa Top
Compacto HPL



Beige Beige



Negro Black

Tapa Top
Porcelánico Porcelain



Blanco natural 81
Natural white 81



Gris claro 80
Light grey 80

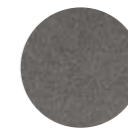

Gris lava 82
Lava grey 82



Corten 83
Corten 83



Negro 84
Black 84

MESA COMEDOR RECTANGULAR
240 x 100 x 74 cm
RECTANGULAR DINING TABLE
94.5 x 39.4 x 29.1 in

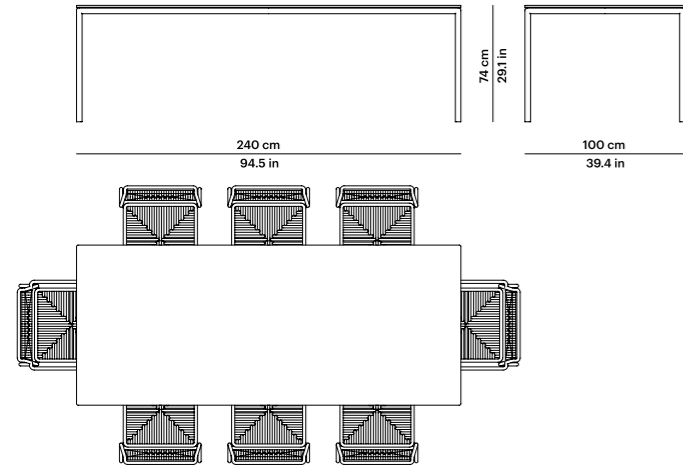

Ref. 77909

Peso Weight **149 Kg con tapa porcelánico**
328.5 lb with porcelain top
122,6 Kg con tapa compacto
270.3 lb with HPL top
m³ **2,34 m³**

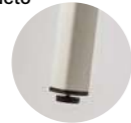

Patas regulables
Adjustable legs

Materiales y acabados
Materials and finishes

Estructura Frame
Aluminio pintado en polvo
Powder coated aluminium



Crema 34
Cream 34



Gris metalizado 56
Gunmetal grey 56

Tapa Top
Compacto HPL



Beige Beige



Negro Black

Tapa Top
Porcelánico Porcelain



Blanco natural 81
Natural white 81



Gris claro 80
Light grey 80

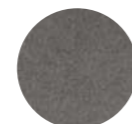

Gris lava 82
Lava grey 82



Corten 83
Corten 83



Negro 84
Black 84

SILLÓN | LOUNGE CHAIR

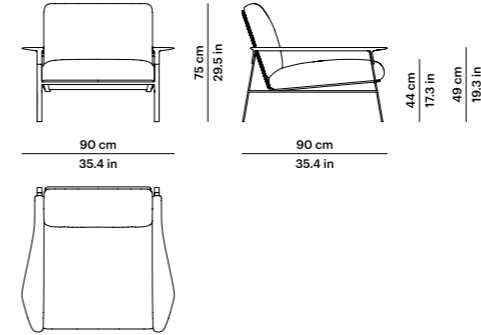

Ref. 78345

Peso Weight **26,6 Kg 58.6 lb**
m³ **0,85 m³**
Cuadrantes Scatter cushions **1 (60x35)**

SOFÁ 2 | SOFA 2

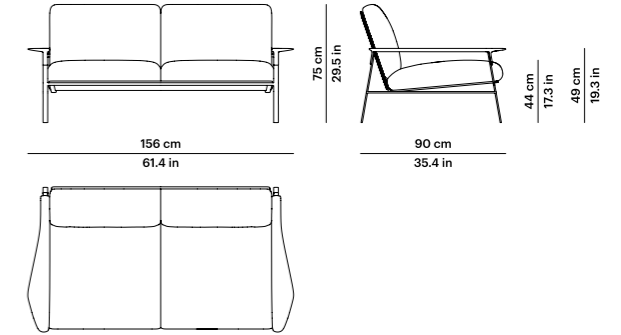

Ref. 78347

Peso Weight **45,5 Kg 100 lb**
m³ **1,41 m³**
Cuadrantes Scatter cushions **2 (60x35)**

SOFÁ 3 | SOFA 3

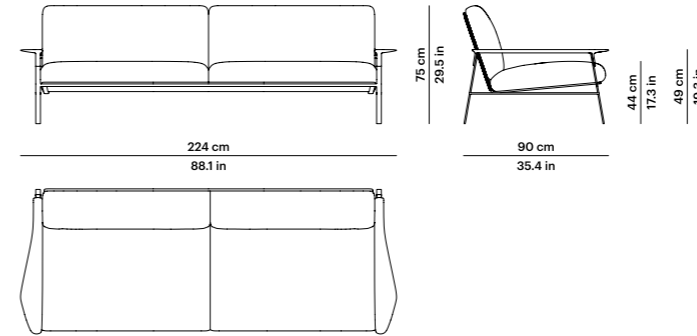

Ref. 78349

Peso Weight **57,8 Kg 127.4 lb**
m³ **2 m³**
Cuadrantes Scatter cushions **2 (60x35)**

Materiales y acabados
Materials and finishes

Estructura Frame



Teca natural
Natural teak

Aluminio Aluminium
Cuerda Ø4 mm Rope Ø4 mm

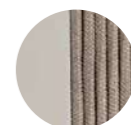

Crema 34 Cream 34
Beige Beige



Arena 74 Sand 74
Gris perlado
Pearl grey

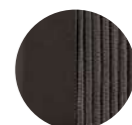

Gris metalizado 56
Gunmetal grey 56
Grafito Graphite

MESA CENTRO CUADRADA
100 x 100 x 20,2 cm
SQUARE COFFEE TABLE
39.4 x 39.4 x 7.9 in

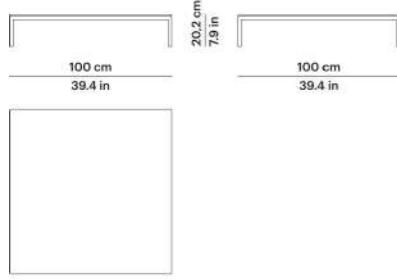

Ref. 78353

Peso Weight 39,2 Kg con tapa porcelánico
86.4 lb with porcelain top
28,2 Kg con tapa compacto
62.2 lb with HPL top
m³ 0,42 m³

MESA CENTRO RECTANGULAR
120 x 70 x 20,2 cm
RECTANGULAR COFFEE TABLE
47.2 x 27.5 x 7.9 in

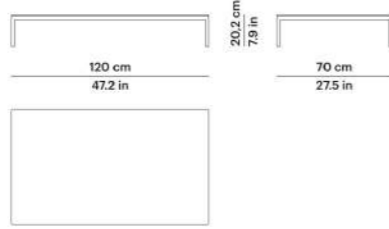

Ref. 78354

Peso Weight 37,1 Kg con tapa porcelánico
81.8 lb with porcelain top
28,7 Kg con tapa compacto
61.3 lb with HPL top
m³ 0,36 m³

MESA RINCÓN CUADRADA
56 x 56 x 52,2 cm
SQUARE SIDE TABLE
22 x 22 x 20.5 in

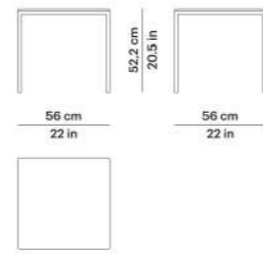

Ref. 78356

Peso Weight 16,7 Kg con tapa porcelánico
36.8 lb with porcelain top
13,3 Kg con tapa compacto
29.3 lb with HPL top
m² 0,28 m²

MESA RINCÓN REDONDA
Ø 70 x 52,2 cm
ROUND SIDE TABLE
Ø 27.5 x 20.5 in

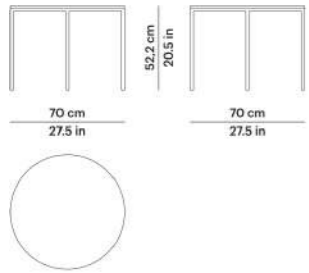

Ref. 78357

Peso Weight 20,8 Kg con tapa porcelánico
45.8 lb with porcelain top
15,4 Kg con tapa compacto
34 lb with HPL top
m³ 0,41 m³

Materiales y acabados
Materials and finishes

Estructura Frame
Aluminio pintado en polvo
Powder coated aluminium



Crema 34
Cream 34



Arena 74
Sand 74



Gris metalizado 56
Gunmetal grey 56

Tapa Top
Compacto HPL



Beige Beige



Negro Black

Tapa Top
Porcelánico Porcelain



Blanco natural 81
Natural white 81



Gris claro 80
Light grey 80



Gris lava 82
Lava grey 82



Corten 83
Corten 83



Negro 84
Black 84

SILLÓN | LOUNGE CHAIR

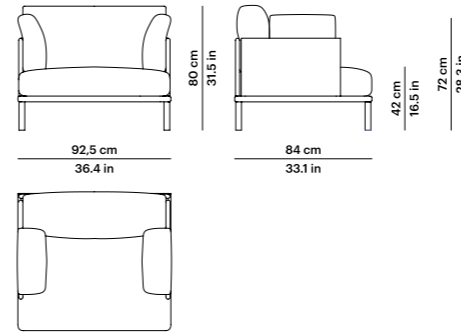

Ref. 77845

Peso Weight 29 Kg 63.9 lb
m³ 0,63 m³
Cuadrantes Scatter cushions 1 (55x30)



Patas regulables
Adjustable legs

SOFA 2 | SOFA 2

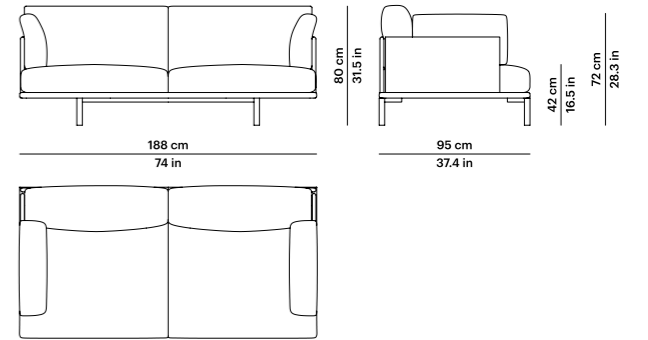

Ref. 77847

Peso Weight 52,2 Kg 115.1 lb
m³ 1,35 m³
Cuadrantes Scatter cushions 1 (60x35)
2 (40x40)
1 (50x50)



Patas regulables
Adjustable legs

SOFA 3 | SOFA 3

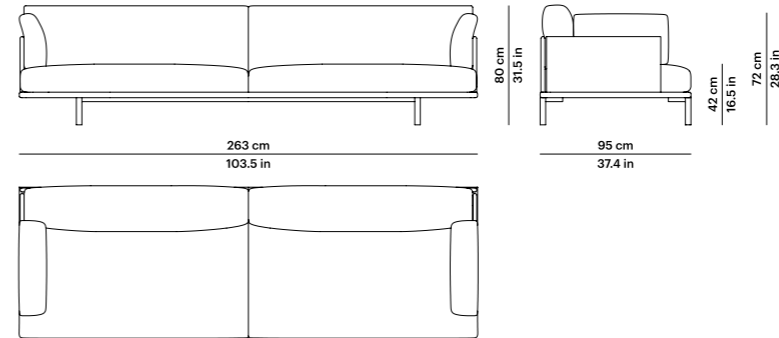

Ref. 77849

Peso Weight 83,2 Kg 183.4 lb
m³ 1,86 m³
Cuadrantes Scatter cushions 1 (60x35)
2 (40x40)
1 (50x50)
1 (60x60)



Patas regulables
Adjustable legs

Materiales y acabados
Materials and finishes

Estructura Frame
Aluminio pintado en polvo
Powder coated aluminium

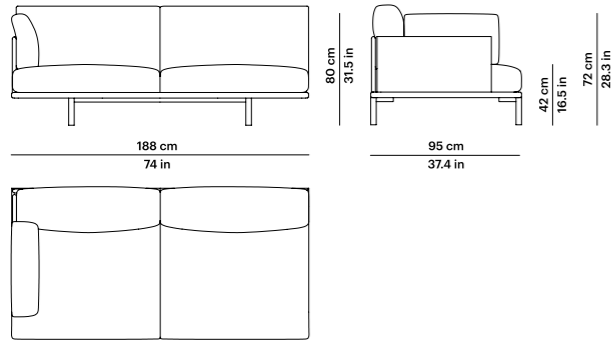

Gris metalizado 56
Gunmetal grey 56

SOFÁ 2 MOD. BRAZO DCHO. | SOFA 2 MOD. RIGHT ARM

Ref. 77840

Peso Weight **49,8 Kg 109.8 lb**
 m³ **1,35 m³**
 Cuadrantes Scatter cushions **1 (60x35)**
1 (40x40)

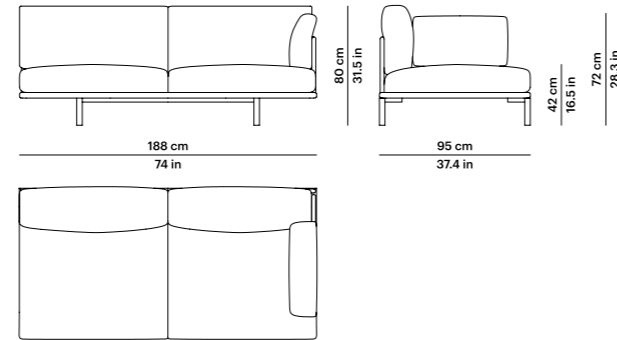

Patas regulables
Adjustable legs

SOFÁ 2 MOD. BRAZO IZQDO. | SOFA 2 MOD. LEFT ARM

Ref. 77841

Peso Weight **49,8 Kg 109.8 lb**
 m³ **1,35 m³**
 Cuadrantes Scatter cushions **1 (60x35)**
1 (40x40)

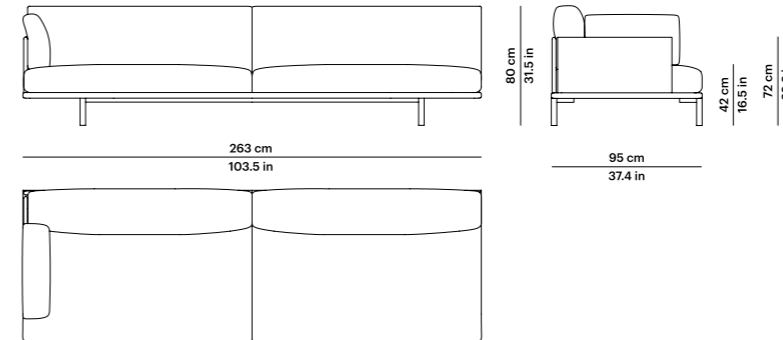

Patas regulables
Adjustable legs

SOFÁ 3 MOD. BRAZO DCHO. | SOFA 3 MOD. RIGHT ARM

Ref. 77842

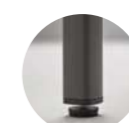
Peso Weight **80,8 Kg 178.1 lb**
 m³ **1,86 m³**
 Cuadrantes Scatter cushions **1 (60x35)**
1 (40x40)
1 (50x50)

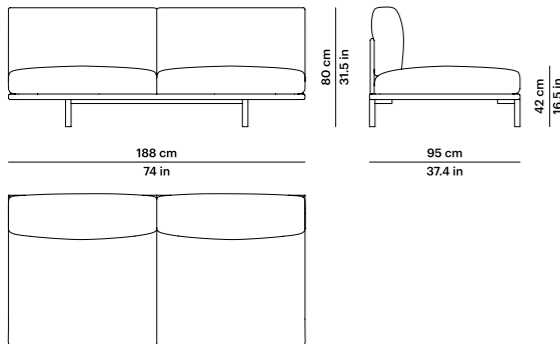

Patas regulables
Adjustable legs

SOFÁ 2 MOD. SIN BRAZOS | SOFA 2 MOD. WITHOUT ARMS

Ref. 77846

Peso Weight **47,4 Kg 104.5 lb**
 m³ **1,35 m³**
 Cuadrantes Scatter cushions **1 (60x35)**
1 (40x40)

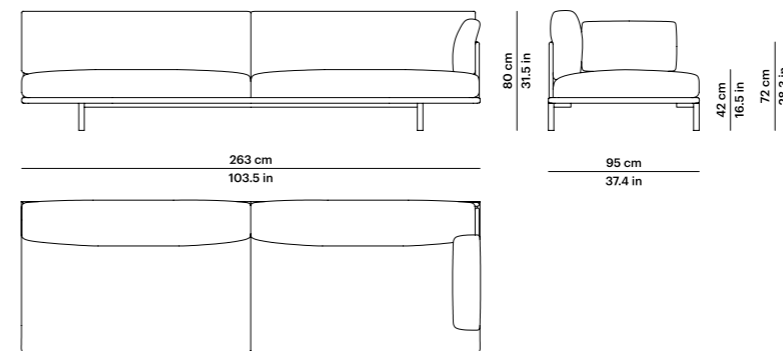

Patas regulables
Adjustable legs

SOFÁ 3 MOD. BRAZO IZQDO. | SOFA 3 MOD. LEFT ARM

Ref. 77843

Peso Weight **80,8 Kg 178.1 lb**
 m³ **1,86 m³**
 Cuadrantes Scatter cushions **1 (60x35)**
1 (40x40)
1 (50x50)



Patas regulables
Adjustable legs

Materiales y acabados
Materials and finishes

Estructura Frame
Aluminio pintado en polvo
Powder coated aluminium



Gris metalizado 56
Gunmetal grey 56

Materiales y acabados
Materials and finishes

Estructura Frame
Aluminio pintado en polvo
Powder coated aluminium



Gris metalizado 56
Gunmetal grey 56

LONG ISLAND

CHRISTOPHE PILLET

SOFÁ 3 MOD. SIN BRAZOS | SOFA 3 MOD. WITHOUT ARMS

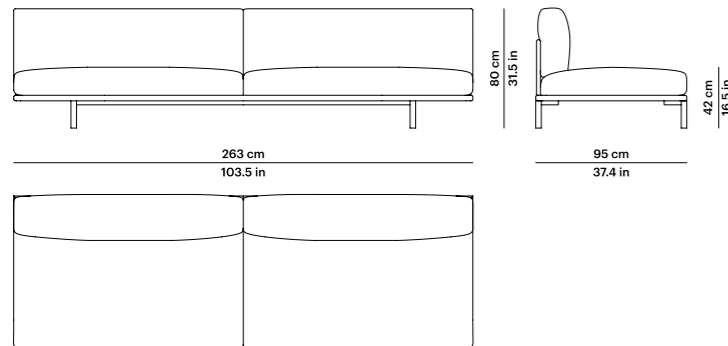

Ref. 77848

Peso Weight
m³ **78,4 Kg 172.8 lb**
Cuadrantes Scatter cushions
1 (40x40)
1 (60x35)
1 (50x50)



Patas regulables
Adjustable legs

MOD. RINCONERA | CORNER MOD.

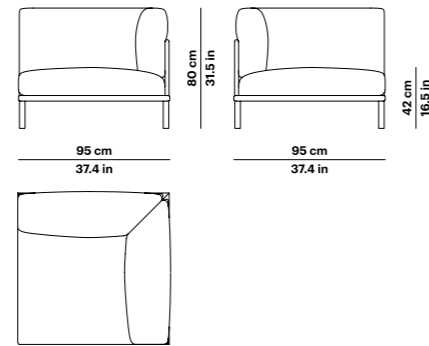

Ref. 77844

Peso Weight
m³ **30 Kg 66.1 lb**
0,72 m³



Patas regulables
Adjustable legs

CHAISE LONGUE BRAZO DCHO. CHAISE LONGUE RIGHT ARM

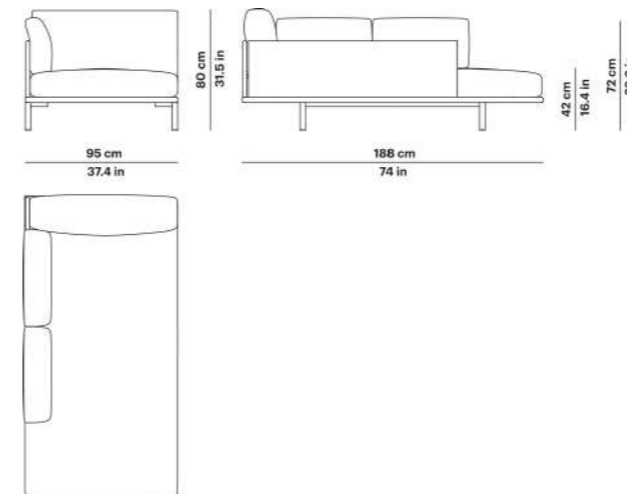

Ref. 77896

Peso Weight
m³ **48,8 Kg 107.6 lb**
Cuadrantes Scatter cushions
1 (50x50)
1 (60x60)



Patas regulables
Adjustable legs

CHAISE LONGUE BRAZO IZQDO. CHAISE LONGUE LEFT ARM

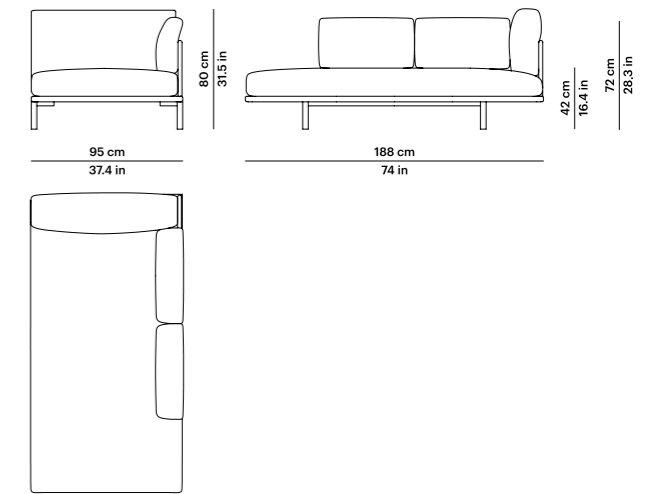

Ref. 77897

Peso Weight
m³ **48,8 Kg 107.6 lb**
Cuadrantes Scatter cushions
1 (50x50)
1 (60x60)



Patas regulables
Adjustable legs

Materiales y acabados Materials and finishes

Estructura Frame
Aluminio pintado en polvo
Powder coated aluminium



Gris metalizado 56
Gunmetal grey 56

Materiales y acabados Materials and finishes

Estructura Frame
Aluminio pintado en polvo
Powder coated aluminium



Gris metalizado 56
Gunmetal grey 56

LONG ISLAND

CHRISTOPHE PILLET

MESA CENTRO CUADRADA
100 x 100 x 37,2 cm
SQUARE COFFEE TABLE
39.4 x 39.4 x 14.6 in

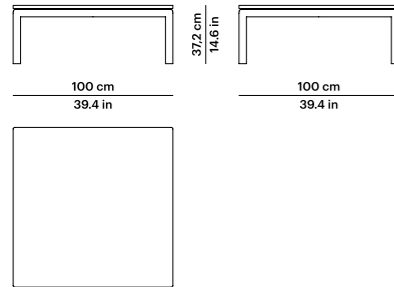

Ref. 77853

Peso Weight 43,4 Kg con tapa porcelánico
95.7 lb with porcelain top
25 Kg con tapa compacto
55.1 lb with HPL top
m³ 0,46 m³



Patas regulables
Adjustable legs

MESA CENTRO RECTANGULAR
120 x 70 x 37,2 cm
RECTANGULAR COFFEE TABLE
47.2 x 27.5 x 14.6 in

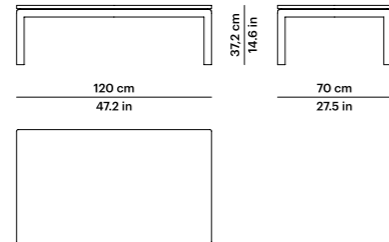

Ref. 77854

Peso Weight 39,9 Kg con tapa porcelánico
88 lb with porcelain top
25 Kg con tapa compacto
55.1 lb with HPL top
m³ 0,49 m³



Patas regulables
Adjustable legs

MESA RINCÓN CUADRADA
70 x 70 x 53,2 cm
SQUARE SIDE TABLE
27.5 x 27.5 x 20.9 in

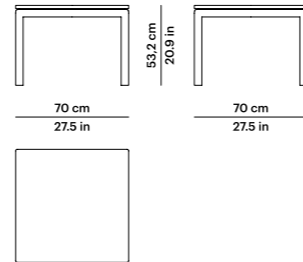

Ref. 77856

Peso Weight 24,6 Kg con tapa porcelánico
54.2 lb with porcelain top
14,8 Kg con tapa compacto
32.6 lb with HPL top
m³ 0,4 m³

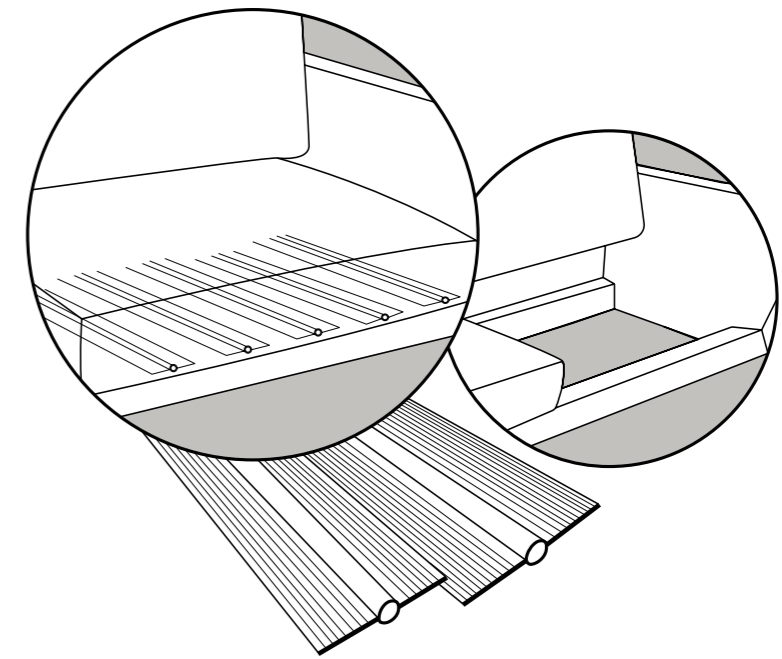

Patas regulables
Adjustable legs

CITY
LONG ISLANDMétodo de
suspensión con lamas
Slatted support system

Método de suspensión con lamas de polipropileno reforzadas con fibra de vidrio. Material 100% reciclado.

Estas dos colecciones, City & Long Island, cuentan con el método de lamas GOODSIDE. Se trata de un método de suspensión con lamas que se combinan con espuma. Las lamas se insertan entre dos capas de espuma cortada consiguiendo así mayor resistencia.

Se trata de un material absolutamente higiénico ya que no absorbe humedad y se puede limpiar con detergentes de limpieza normales sin dañar la superficie.

Los listones GOODSIDE resistentes a la intemperie permiten el uso en exteriores durante todo el año.

Los cojines con este sistema llevan siempre incluida la funda impermeable.

Method of suspension with fibre-glass-reinforced polypropylene slats. 100% recycled material.

These two collections, City & Long Island, feature the GOODSIDE slat method. It is a suspension solution that uses slats combined with foam. The slats are inserted between two layers of cut foam for increased strength.

This is an absolutely hygienic material as it does not absorb moisture and can be cleaned with normal cleaning detergents without damaging the surface.

Weatherproof GOODSIDE slats can be used outdoors all year round.

With this system, the cushions always include a waterproof cover.

Materiales y acabados
Materials and finishes

Estructura Frame
Aluminio pintado en polvo
Powder coated aluminium



Gris metalizado 56
Gunmetal grey 56

Tapa Top
Compacto HPL



Beige Beige



Negro Black

Tapa Top
Porcelánico Porcelain



Blanco natural 81
Natural white 81



Gris claro 80
Light grey 80

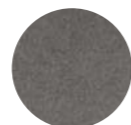

Gris lava 82
Lava grey 82



Corten 83
Corten 83



Negro 84
Black 84

GOODSIDE



COMPOSICIÓN 1 | COMPOSITION 1

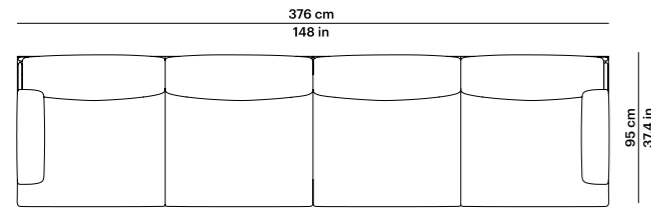

Uds.	Units	Ref.	Descripción	Description
1		77841	Sofá 2 Modular Brazo Izquierdo	Sofa 2 Modular Left Arm
1		77840	Sofá 2 Modular Brazo Derecho	Sofa 2 Modular Right Arm

Peso Weight
m³ **99,6 Kg 219.6 lb**
2,7 m³

COMPOSICIÓN 2 | COMPOSITION 2

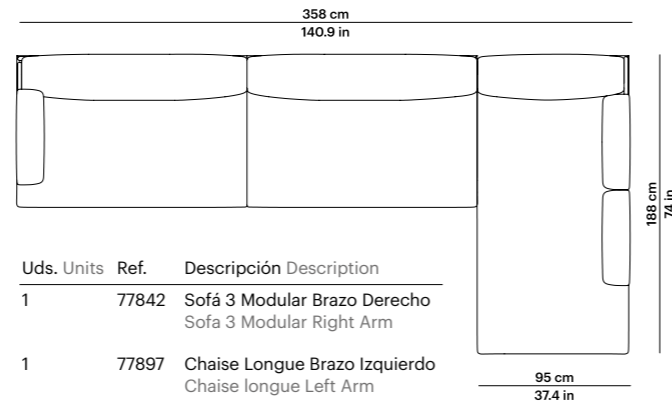

Uds.	Units	Ref.	Descripción	Description
1		77842	Sofá 3 Modular Brazo Derecho	Sofa 3 Modular Right Arm
1		77897	Chaise Longue Brazo Izquierdo	Chaise longue Left Arm

Peso Weight
m³ **129,6 Kg 285.7 lb**
3,2 m³

COMPOSICIÓN 3 | COMPOSITION 3

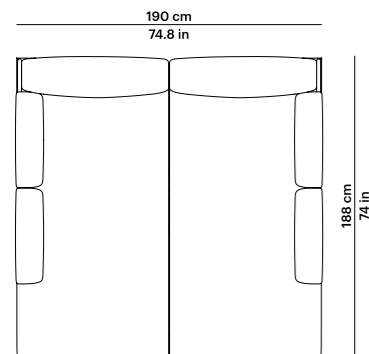

Uds.	Units	Ref.	Descripción	Description
1		77896	Chaise Longue Brazo Derecho	Chaise Longue Right Arm
1		77897	Chaise Longue Brazo Izquierdo	Chaise Longue Left Arm

Peso Weight
m³ **97,6 Kg 215.2 lb**
2,7 m³

COMPOSICIÓN 4 | COMPOSITION 4

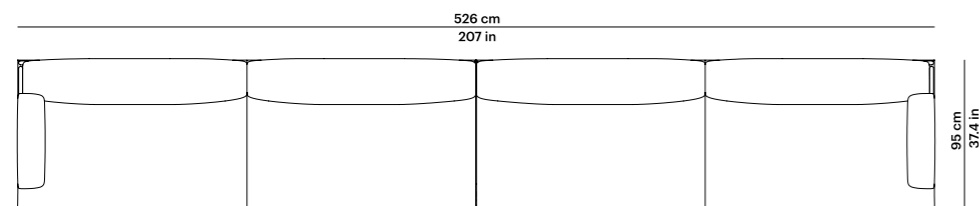

Uds.	Units	Ref.	Descripción	Description
1		77843	Sofá 3 Mod. Brazo Izq.	Sofa 3 Mod. Left Arm
1		77842	Sofá 3 Mod. Brazo Dcho.	Sofa 3 Mod. Right Arm

Peso Weight
m³ **161,6 Kg 356 lb**
3,72 m³

COMPOSICIÓN 5 | COMPOSITION 5

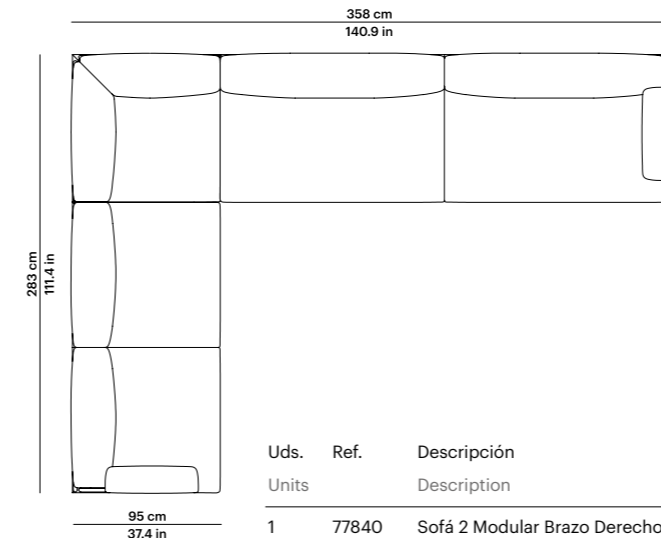

Uds.	Units	Ref.	Descripción	Description
1		77840	Sofá 2 Modular Brazo Derecho	Sofa 2 Modular Right Arm
1		77844	Módulo Rinconera	Corner Modular
1		77843	Sofá 3 Modular Brazo Izquierdo.	Sofa 3 Modular Left Arm

Peso Weight
m³ **160,6 Kg 354 lb**
3,93 m³

COMPOSICIÓN 6 | COMPOSITION 6

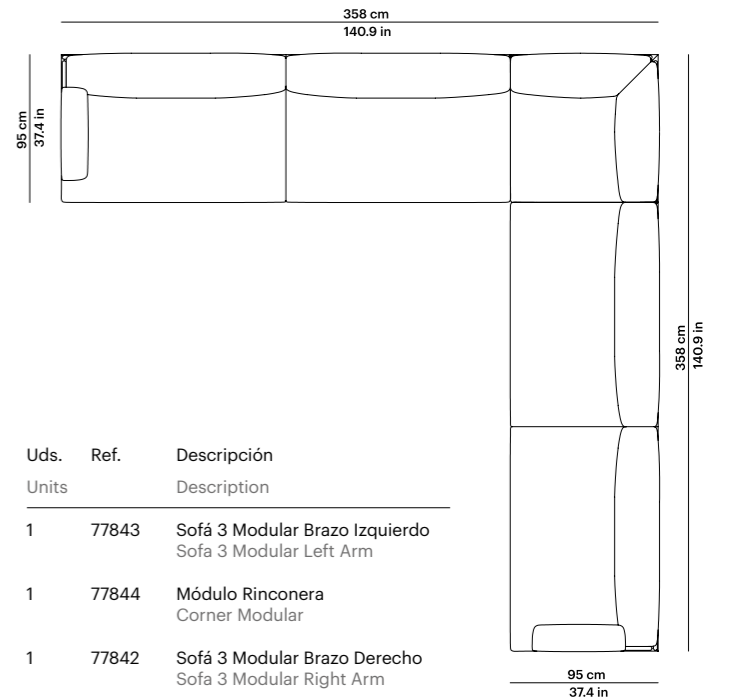

Uds.	Units	Ref.	Descripción	Description
1		77843	Sofá 3 Modular Brazo Izquierdo	Sofa 3 Modular Left Arm
1		77844	Módulo Rinconera	Corner Modular
1		77842	Sofá 3 Modular Brazo Derecho	Sofa 3 Modular Right Arm

Peso Weight
m³ **191,6 Kg 422.4 lb**
4,44 m³

COMPOSICIÓN 7 | COMPOSITION 7

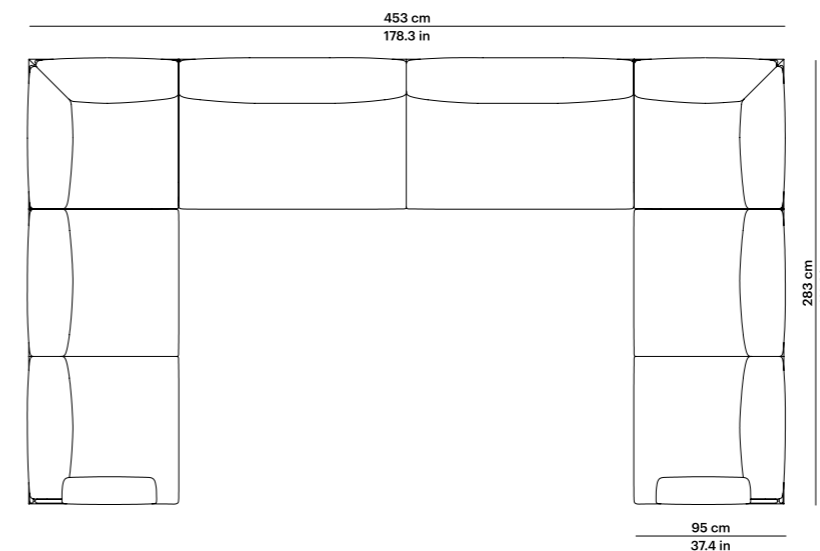

Uds.	Units	Ref.	Descripción	Description
1		77840	Sofá 2 Mod. Brazo Dcho.	Sofa 2 Mod. Right Arm
2		77844	Módulo Rinconera	Corner Modular
1		77848	Sofá 3 Mod. Sin Brazos	Sofa 3 Mod. Without Arms
1		77841	Sofá 2 Mod. Brazo Izq.	Sofa 2 Mod. Left Arm

Peso Weight
m³ **238 Kg 524.7 lb**
6 m³

SILLA | SIDE CHAIR

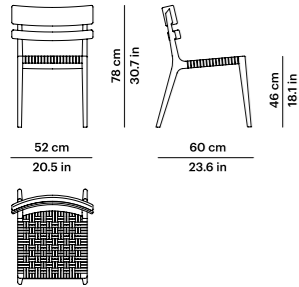

Ref. 77601

Peso Weight 8 Kg 17.6 lb (1 pc)
18 Kg 39.7 lb (2 pcs)
m³ 0,29 m³ (1 pc) - 0,46 m³ (2 pcs)

SILLÓN COMEDOR | ARMCHAIR

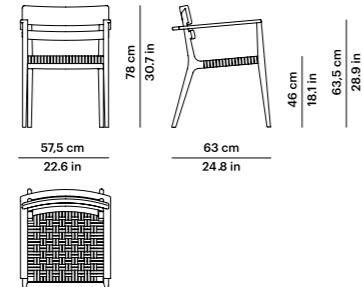

Ref. 77606

Peso Weight 9,7 Kg 21.4 lb (1 pc)
21 Kg 46.3 lb (2 pcs)
m³ 0,35 m³ (1 pc) - 0,55 m³ (2 pcs)

TABURETE | STOOL

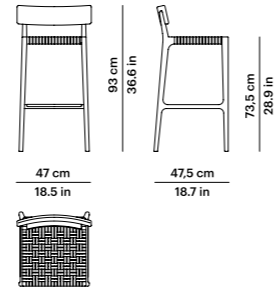

Ref. 77652

Peso Weight 8 Kg 17.6 lb
m³ 0,26 m³

SILLÓN | LOUNGE CHAIR

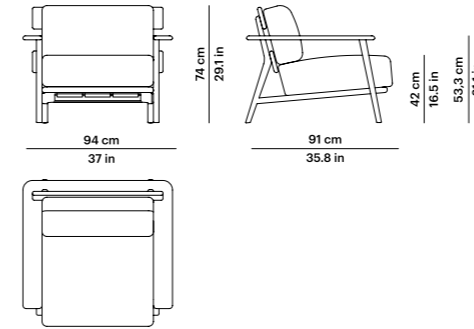

Ref. 77645

Peso Weight 32,8 Kg 72,3 lb
m³ 0,87 m³
Cuadrantes Scatter cushions 1 (40x40)

SILLÓN CLUB | CLUB SMALL LOUNGE CHAIR

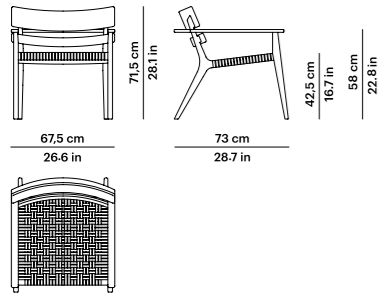

Ref. 77605

Peso Weight 11 Kg 24.3 lb (1 pc)
24 Kg 52.9 lb (2 pcs)
m³ 0,36 m³ (1 pc) - 0,71 m³ (2 pcs)

SOFÁ 2 | SOFA 2

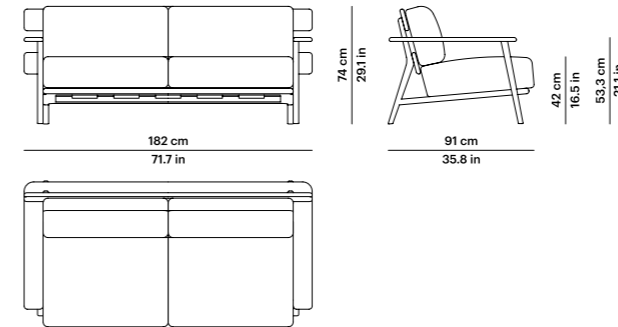

Ref. 77647

Peso Weight 49 Kg 108 lb
m³ 1,3 m³
Cuadrantes Scatter cushions 2 (40x40)

SOFÁ 3 | SOFA 3

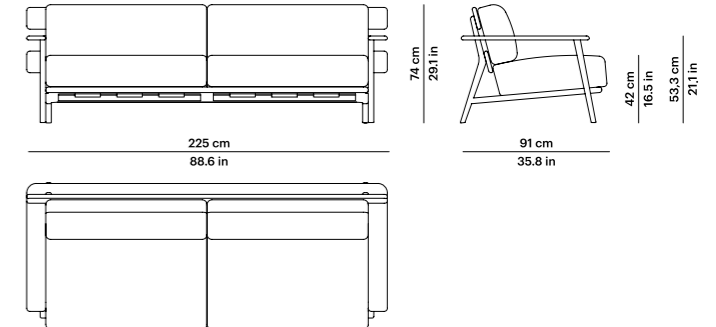

Ref. 77649

Peso Weight 74,4 Kg 164 lb
m³ 1,92 m³
Cuadrantes Scatter cushions 3 (40x40)

Materiales y acabados Materials and finishes

Estructura Frame



Teca natural
Natural teak

Trenzado
Weave



Cuerda sintética Ø 4 mm
Synthetic cord Ø 4 mm

Materiales y acabados Materials and finishes

Estructura Frame



Teca natural
Natural teak

MESA CLUB
 Ø 77,5 x 55,5 cm
 ROUND COFFEE TABLE
 Ø 30.5 x 21.9 in

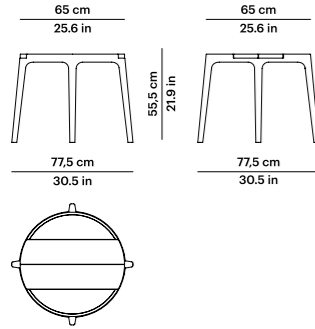

Ref. 77615

Peso Weight **13,5 Kg 29.8 lb**
 m³ **0,25 m³**



Patas regulables
 Adjustable legs

MESA RINCÓN
 74 x 74 x 56 cm
 SQUARE SIDE TABLE
 29.1 x 29.1 x 22 in

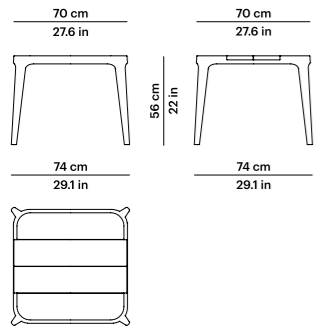

Ref. 77656

Peso Weight **17 Kg 37.5 lb**
 m³ **0,29 m³**



Patas regulables
 Adjustable legs

MESA CENTRO RECTANGULAR
 141 x 72 x 40 cm
 RECTANGULAR COFFEE TABLE
 55.5 x 28.3 x 15.7 in

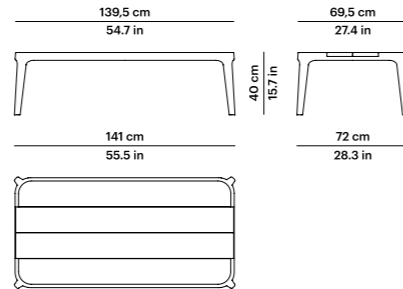

Ref. 77654

Peso Weight **25 Kg 55.1 lb**
 m³ **0,42 m³**



Patas regulables
 Adjustable legs

Materiales y acabados
 Materials and finishes

Estructura Frame



Teca natural
 Natural teak

MESA COMEDOR CUADRADA
 107 x 107 x 72,5 cm
 SQUARE DINING TABLE
 42.1 x 42.1 x 28.5 in

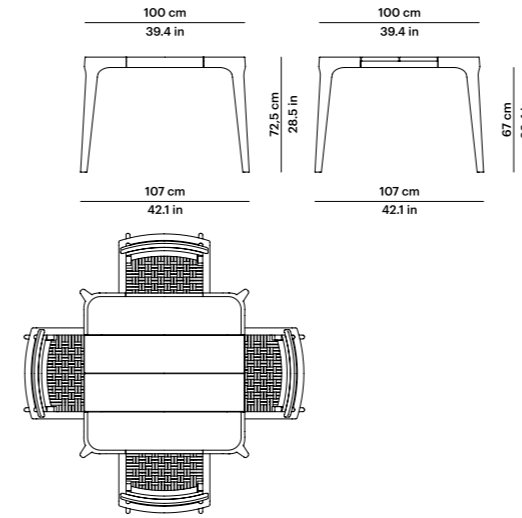

Ref. 77610

Peso Weight **37 Kg 81.6 lb**
 m³ **0,36 m³**



Patas regulables
 Adjustable legs

Materiales y acabados
 Materials and finishes

Estructura Frame



Teca natural
 Natural teak

MESA COMEDOR REDONDA
 Ø 130,5 x 72,5 cm
 ROUND DINING TABLE
 Ø 51.4 x 28.5 in

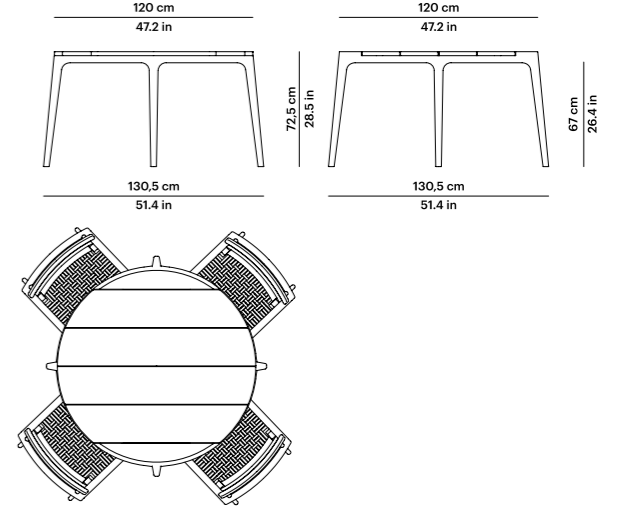

Ref. 77611

Peso Weight **37 Kg 81.6 lb**
 m³ **1,1 m³**



Patas regulables
 Adjustable legs

PARALEL

GABRIEL TEIXIDÓ

MESA COMEDOR RECTANGULAR
187 x 107 x 72,5 cm
RECTANGULAR DINING TABLE
73.6 x 42.1 x 28.5 in

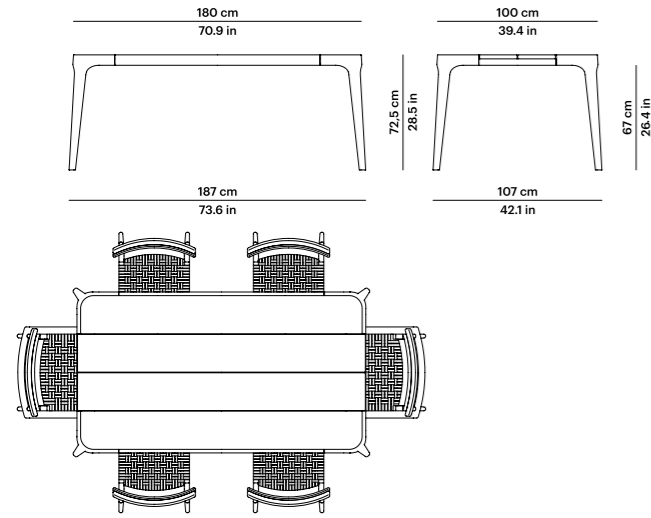

Ref. 77609

Peso Weight 58 Kg 127.9 lb
m³ 0,64 m³

Patas regulables
 Adjustable legs

MESA COMEDOR RECTANGULAR
226 x 109 x 72,5 cm
RECTANGULAR DINING TABLE
89 x 42.9 x 28.5 in

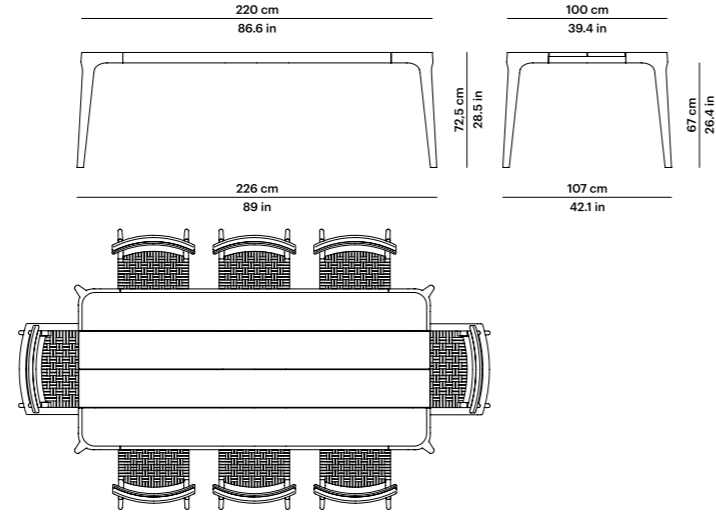

Ref. 77608

Peso Weight 66 Kg 145.5 lb
m³ 0,78 m³

Patas regulables
 Adjustable legs

FUP

FRANCESC RIFÉ

PUF | OTTOMAN

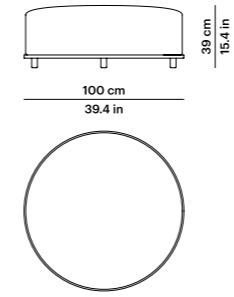

Ref. 77752

Peso Weight 25,8 Kg 56.9 lb
m³ 0,46 m³

PUF | OTTOMAN

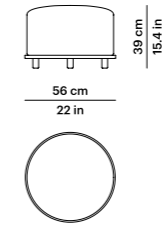

Ref. 77751

Peso Weight 8,4 Kg 18.5 lb
m³ 0,18 m³

Materiales y acabados
 Materials and finishes

Estructura Frame



Teca natural
 Natural teak

Materiales y acabados
 Materials and finishes

Estructura Frame



Teca natural
 Natural teak

ACABADOS Y
MANTENIMIENTO

FINISHES AND
MAINTENANCE

Cuerda Rope

Tanto el ánima como el recubrimiento del cordón es de polipropileno para conseguir una mayor solidez a la luz e intemperie. Además, lleva un filtro de color para mayor fijación.

Limpieza y mantenimiento

Utilizar solución jabonosa de pH neutro para la limpieza de residuos o manchas. Evitar el contacto con productos abrasivos (lejías, cloro, aceites, productos con ácidos o sustancias corrosivas en su composición).

Both the rope itself and its coating are made from polypropylene to ensure greater resistance to light and weather. It also includes a colour filter for greater fixing.

Maintenance and cleaning

A soapy solution with a neutral pH can be used to clean any dirt or marks. Avoid contact with abrasive products (bleach, chlorine, oils, products containing acids or corrosive substances).

**Shintotex®
Advanced synthetic fibres**

Es la fibra sintética para muebles de exterior inspirada en la naturaleza y perfeccionada técnicamente hasta alcanzar el máximo nivel de confort, funcionalidad y durabilidad. El Shintotex® está compuesto por PP y PE más componentes catalizadores como filtros UV, pigmentos, aditivos anti-estáticos y elementos plastificantes.

Características técnicas:

Resistencia a cambios climatológicos.
Resistencia a agentes químicos abrasivos.
Resistencia a rotura y deterioro por el uso.
Alta flexibilidad.
Total reciclaje.

Características estéticas:

Calidez y apariencia natural.
Tacto agradable.
Variedad de texturas y trenzados.
Fácil limpieza.
Mayor ligereza.

Limpieza y mantenimiento

Pasar cepillo de cerdas suaves sobre el tejido para eliminar el polvo o utilizar solución jabonosa de pH neutro para la limpieza de residuos o manchas. Evitar el contacto con productos abrasivos (lejías, cloro, aceites, productos con ácidos o sustancias corrosivas en su composición).

This is a synthetic fibre for outdoor furniture, inspired by nature and perfected by technology to achieve maximum comfort, functionality and durability. Shintotex® is made of PP and PE, as well as catalysts, such as UV filters, pigments, additives, anti-static agents and plasticisers.

Technical features:

Resistant to changing weather conditions.
Resistant to abrasive chemical agents.
Resistant to breakage and to wear and tear.
Highly flexible.
Fully recyclable.

Aesthetic features:

Warm, natural appearance.
Pleasant to the touch.
Variety of textures and braids.
Easy to clean.
Lighter weight.

Maintenance and cleaning

Use a soft-bristled brush to remove any dust from the weave. Also, a soapy solution of neutral pH can be used to clean any residue or marks. Avoid contact with abrasive products (bleach, chlorine, oils, products containing corrosive acids or substances).

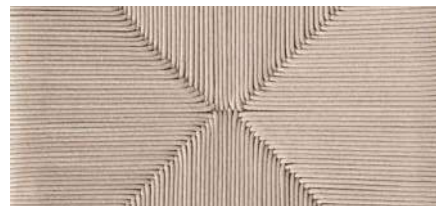

Beige
Beige



Gris perlado
Pearl grey

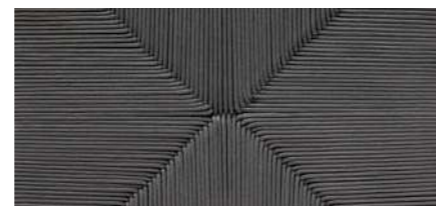

Grafito
Graphite



Blanco
White



Gris plata
Silver grey



Marrón castaño
Chestnut brown



Gris oscuro
Dark grey

Teca Teak

Madera de Teca de Grado A

POINT utiliza madera teca de grado A de origen asiático, procedente de bosques sostenibles de talas controladas. Esta materia prima contiene un alto nivel de aceite y gomas naturales, lo que le otorga al material una alta flexibilidad y durabilidad muy idónea para los productos de exterior. Esta madera tropical, que transmite naturalidad en todos sus detalles, está dotada de un aceite natural propio, que le aporta un brillo singular y la hace perfecta para el mobiliario de exterior.

La madera de teca refleja el compromiso de POINT con materiales naturales de gran calidad. Los procesos artesanales de POINT consiguen que la madera de teca revele un brillo y un color muy consistente. Su aceite natural se conjuga con una resina antiséptica propia para asegurar que el paso del tiempo se convierta en un aliado de la pieza.

Limpieza y mantenimiento

Si el mueble de Teca ha estado expuesto a los elementos y se deja sin tratamiento, ambas maderas se enfrentaran a una pátina de color gris plateado después de unos meses. Este cambio en la apariencia de la madera no afecta a la integridad estructural de los muebles. En este caso, únicamente deberá limpiar a fondo una o dos veces al año, con agua tibia y jabón neutro, frotando con una esponja.

Si desea conservar el color dorado-marrón de estas maderas nuevas recomendamos el producto sellador de POINT (aceite de teca). Este tipo de productos no afectará a la resistencia o longevidad de los muebles, únicamente a su apariencia. Se recomienda aplicar el sellador de teca dos veces al año aproximadamente.



Teca
Teak

Grade A Teak Wood

POINT uses grade A teak wood from Asia. It is sourced from carefully managed sustainable forests. This raw material contains a high level of natural oil and gums, making it a highly flexible and durable material that is ideal for outdoor furniture. This tropical wood, which is natural in every way, has its own natural oil that gives it a unique sheen and makes it perfect for outdoor furniture.

Teak wood reflects POINT's commitment to using high-quality natural materials. Thanks to the traditional processes used at POINT, the sheen of the teak wood comes through, offering a very consistent colour. Its natural oil is combined with an antiseptic resin in the wood to enhance the beauty of the piece over time.

Maintenance and cleaning

If Teak furniture has been exposed to weather and left untreated, the wood will show a silvery grey patina after a few months. This change in wood appearance does not affect the structural integrity of the furniture. In this case, you only have to clean it thoroughly once or twice a year with warm water and a mild soap, scrubbing it with a sponge.

If you want to preserve the golden-brown colour of these new woods, we recommend the POINT sealant (teak oil). This type of product does not affect the strength or longevity of the furniture, only its appearance. It is recommended to apply the teak sealant twice a year or so.

Cuerda Sintética Synthetic Rope

Cuerda sintética para muebles de exterior compuesta de polietileno de alta densidad. Cuenta con un alto nivel de confort, funcionalidad y durabilidad.

Características técnicas:

Resistencia a cambios climatológicos.
Resistencia a rotura y deterioro por el uso.
Alta flexibilidad.
Total reciclaje.

Características estéticas:

Calidez y apariencia natural.
Tacto agradable.
Fácil limpieza.
Mayor ligereza.

Limpieza y mantenimiento

Pasar cepillo de cerdas suaves sobre la cuerda para eliminar el polvo, o utilizar solución jabonosa de pH neutro para la limpieza de residuos o manchas. Evitar el contacto con productos abrasivos (lejías, cloro, aceites, productos con ácidos o sustancias corrosivas en su composición).

Synthetic rope for outdoor furniture. A high-density polyethylene compound that offers a high level of comfort, functionality and durability.

Technical features:

Resistant to changing weather conditions.
Resistant to breakage and to wear and tear.
Highly flexible.
Totally recycled.

Aesthetic features:

Warm, natural appearance.
Pleasant to the touch.
Easy to clean.
Lighter weight.

Maintenance and cleaning

Brush the rope with a soft-bristled brush to remove any dust, or use a soapy solution with a neutral pH to clean any residue or marks. Avoid contact with abrasive products (bleach, chlorine, oils, products containing acids or corrosive substances).

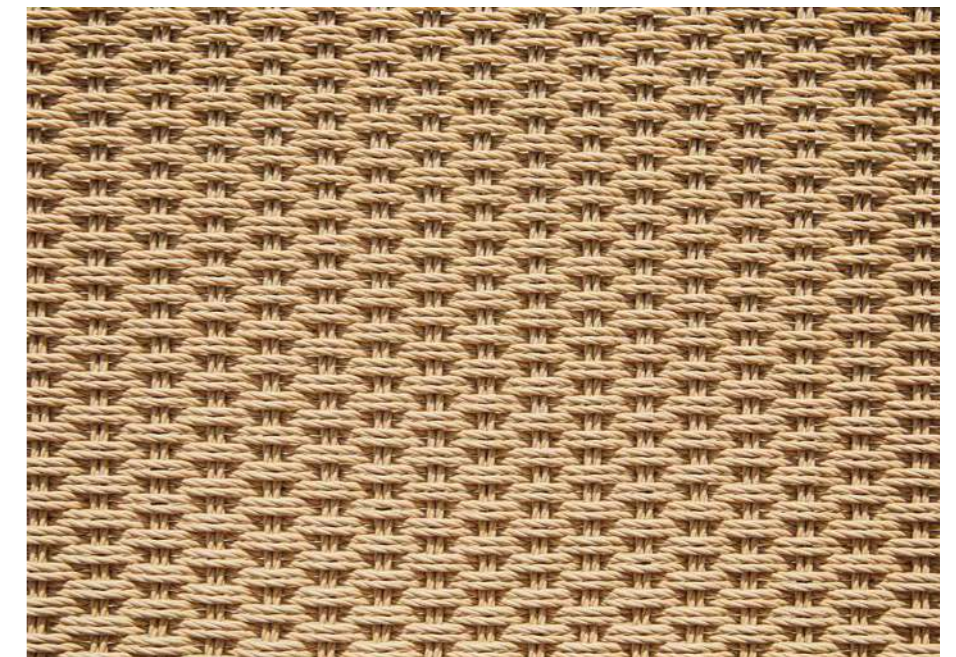

Trenzado Cuerda sintética Ø 4 mm
Woven Synthetic cord Ø 4 mm

Aluminio pintado en polvo Powder coated aluminium

Con resina epóxica como ligante, para incrementar la resistencia a la corrosión, abrasión y a los agentes químicos.

Limpieza y mantenimiento

Utilizaremos bayetas suaves o esponjas que no rayen la superficie y agua con jabón o detergentes neutros diluidos en agua; nunca productos abrasivos. Después se enjuagará con agua limpia y se secará con un paño, para evitar que el detergente afecte al material.

With epoxy resin used as a binder to increase resistance to corrosion, abrasion and chemical agents.

Maintenance and cleaning

Use soft cloths or sponges that will not scratch the surface with soap and water or neutral detergents diluted in water; never use abrasive products. Then rinse with clean water and dry with a cloth to prevent the detergent from affecting the material.



Crema 34
Cream 34



Arena 74
Sand 74



Gris metalizado 56
Gunmetal grey 56

Porcelánico Porcelain

Se trata de un material porcelánico elaborado de 12 mm de espesor.

Características técnicas:

Impermeable y resistente a líquidos, con un nivel de absorción próximo a cero. Resistente al rayado y a la abrasión gracias a la dureza de su superficie. No se quema en contacto con el fuego ni emite humo ni sustancias tóxicas al ser sometido a altas temperaturas. Resistente a cualquier tipo de agente químico de limpieza. No desprende sustancias nocivas. Es totalmente apto para el contacto con los alimentos. Certificado NSF. Siendo 100% natural, los colores no se desvirtúan cuando el material se expone al sol o a condiciones meteorológicas extremas. No desprende ninguna sustancia nociva para el entorno. Hasta un 52% de material reciclado en cada tabla. 100% reciclable. 30 kg/m² en la tabla de 12 mm. Módulo de rotura elevado. Resistente a altas cargas de presión y peso.

Limpieza y mantenimiento

Tiene una limpieza fácil ya que no pueden penetrar en el material los restos de comida y residuos que se depositen por lo que garantizan una buena higiene. Para la mayoría de los casos, sólo bastará con un paño húmedo para limpiarlo. Use un paño de microfibra para quitar el polvo de la superficie. Se puede lavar con agua tibia, a la cual se le puede agregar un detergente en la dosis de uso recomendado por el fabricante. (Deben evitarse productos que contengan ácido fluorhídrico y sus derivados). Enjuagar con agua tibia y secar con bayetas o algo similar.

This is a 12-mm thick porcelain material.

Technical features:

Waterproof and resistant to liquids, with an absorption level close to zero. Scratch and abrasion resistant thanks to the hardness of the surface. No combustion takes place in contact with fire and no smoke or toxic substances are released when it is subjected to high temperatures. Resistant to any type of chemical or cleaning agent. No dangerous substances are given off. It is totally apt for contact with foodstuffs. NSF certified. As it is 100% natural, the colours do not fade when exposed to sunlight or subjected to extreme weather conditions. No dangerous substances that may harm the environment are given off. Each piece contains up to 52% recycled material. 100% recyclable. 30 kg/m² in a 12 mm piece. Highly resistant to breakage. Resistant to high pressures and loads.

Maintenance and cleaning

Easy to clean, as traces of food and other residues on the surface cannot penetrate the material, thus offering enhanced hygiene; in most cases, it is sufficient to wipe the surface clean with a damp cloth. Use a microfibre cloth to dust the surface. To wash, use lukewarm water; a detergent may be added according to the dosage recommended by the manufacturer (products containing hydrofluoric acid and its derivatives should be avoided). Rinse with lukewarm water and dry with a clean cloth.



Blanco natural 81
Natural white 81



Gris claro 80
Light grey 80



Gris lava 82
Lava grey 82



Corten 83
Corten 83



Negro 84
Black 84

Compacto HPL

Es el material de las tapas de las mesas de algunas colecciones. Se trata de tablero compacto de 10 mm de espesor en calidad standard (CGS) termoendurecido a alta presión en formato 4200x1600 mm con el núcleo compuesto de resinas fenólicas y superficies decorativas impregnadas en resinas melamínicas.

Limpieza y mantenimiento

Las superficies de compacto deben limpiarse con regularidad pero no requieren ningún mantenimiento especial, solo un paño húmedo con agua templada o detergente suave. Se pueden usar perfectamente casi todos los productos de limpieza o desinfectantes domésticos siempre y cuando estos no sean abrasivos o altamente alcalinos.

This is the material used for the table tops of some collections. It is a 10-mm thick, compact board in standard quality (CGS), which was thermoset at high pressure in a 4200x1600 mm mould, with a core made of phenolic resins and decorative surfaces that are impregnated with melamine resins.

Maintenance and cleaning

Surfaces made out of HPL should be cleaned regularly and do not require any special maintenance; just wipe with a damp cloth that has been previously soaked in lukewarm water with a gentle detergent. Almost all kinds of cleaning products can be used without any problem, as long as they are not abrasive or highly alkaline.



Beige
Beige



Negro
Black

Funda de cubrir Protective cover

En POINT recomendamos proteger los muebles de exterior con medidas simples y mejorar así su durabilidad. Para ello, creamos la Protective Cover, una funda protectora especial, disponible en color beige, hecha de poliéster con lacado acrílico. Es resistente al agua y cuenta con un tratamiento fungicida en el interior. Además, es repelente a la suciedad y resistente al frío, al calor y a la intemperie.

Cada pieza cuenta con su propia funda. Además, tiene un cordón que permite ajustar la funda al mueble, alrededor de la base, para que el viento no pueda levantarla.

Para obtener mejores resultados, es conveniente que los muebles, cojines y cuadrantes estén secos antes de cubrirlos para evitar humedad y manchas de moho.

At POINT we recommend simple measures to protect outdoor furniture and make it more durable. For this purpose, we created the Protective Cover, a special protective sheet, available in beige and made from polyester with acrylic lacquer. It is waterproof and treated with a fungicide on the inside. It also repels dirt and is heat, cold and weather resistant.

Each piece comes with its own cover. It also includes a tie so you can adjust the cover to the furniture around the base to secure it against the wind.

For the best results, the furniture and cushions should be dry before they are covered in order to avoid moisture and mould stains.

TELAS

FABRICS

TELAS Grupo 1 FABRICS Group 1



Composición: 100% Acrílico teñido en masa.
Ancho: 160cm
Acabado: hidrófugo con tratamiento antimanchas.
Solidez a la luz: 7/8
Garantía: 5 años.
Tolerancia: valores susceptibles de tolerancia de +/- 5%

Limpieza y mantenimiento

Eliminar la suciedad mediante cepillado o aspirado suave del tejido. Lavar a temperatura máxima de 30° y jabón neutro. No utilizar disolventes ni detergentes abrasivos. No utilizar secadora. Planchado máximo a 150°. No admite lavado en seco.

Composition: 100% solution dyed acrylic.

Width: 160 cm

Finish: water repellent with a stain resistant treatment.

Light fastness: 7/8

Warranty: 5 years.

Tolerance: values subject to +/-5% tolerance

Maintenance and cleaning

Remove dirt by softly brushing or vacuuming the fabric. Wash at 30° max. with a mild soap. Do not use solvents or abrasive detergents. Do not tumble dry. Iron up to 150° max. Do not dry clean.



Resistente al agua
Water resistant



Resistente a las manchas
Stain resistant



Resistente al moho
Mould resistant



Protección UV
UV protection



Resistente a los rayos UV
UV resistant



Fuerte y duradero
Durable and strong



Aislante
Non-conductive



Fácil de limpiar
Easy to clean

TELAS Grupo 2-3 FABRICS Group 2-3



Composición: 100% Acrílico teñido en masa.
Ancho: 137cm EN 1773
Acabado: repelente al agua y antimanchas.
Solidez a la luz: 8/8 (ISO 105 B02)
Solidez de colores a la intemperie: 4-5/5 (ISO 105 B04)
Garantía: 5 años.

Limpieza y mantenimiento

Textiles Sunbrella pueden lavarse a máquina a 40°. Dejar secar al aire. Las tapicerías de tela que no se puedan quitar para el lavado se pueden limpiar con un cepillo y agua jabonosa de cerdas suaves (agregar 50 ml de lejía por litro de agua en caso de manchas difíciles). Enjuague con agua limpia y dejar secar al aire.

Composition: 100% solution dyed acrylic.

Width: 137 cm EN 1773

Finish: water-repellent and stain-proof.

Light fastness: 8/8 (ISO 105 B02)

Weather condition colour fastness: 4-5/5 (ISO 105 B04)

Warranty: 5 years.

Maintenance and cleaning

Wash at 40°. Allow to air dry. Fabric covers that cannot be removed for washing can be cleaned with a soft-bristled brush and soapy water (add 50 ml of bleach per litre of water in case of stubborn stains). Rinse with clean water and allow to air dry.



Limpiables con lejía
Bleach cleanable



Transpirables
Breathable comfort



Resistentes al moho
Mold / mildew resistant



Resistentes a la suciedad
Water & stain resistant



Protegen del sol
Sun protection



UV / resistentes pérdida color
UV / fade resistant

BATYLINE Grupo 2-3 BATYLINE Group 2-3

BATYLINE

TEXYLOOP
A GLOBELCOP INDUSTRY

Serge Ferrari

Composición: Composite PVC – fibras sintéticas.
Ancho: 180cm
Garantía: 5 años.
Reciclabilidad: 100% por el sistema Texyloop.
Sistema de gestión de calidad: ISO 9001
Sistema de gestión medioambiental: ISO 14001

Limpieza y mantenimiento

Quitar el polvo al tejido con un aspirador o un cepillo suave no metálico. Lavar con un cepillo suave o una esponja utilizando agua jabonosa. Aclarar abundantemente con agua clara (chorro de agua). Dejar que se seque bien el tejido al aire libre en posición desplegada. Si el tejido puede desprenderse de su soporte, la limpieza puede realizarse a máquina a una temperatura no superior a 40°C.

Composition: Composite PVC-synthetic fibres.

Width: 180 cm

Warranty: 5 years.

Recyclability: 100% by Texyloop method.

Quality system: ISO 9001

Environmental system: ISO 14001

Maintenance and cleaning

Remove dust from the fabric with a vacuum cleaner or soft, non-metallic brush. Wash with a soft brush or a sponge, using soapy water. Rinse copiously (spray) with clean water. Allow the fabric to air dry completely, well spread out. If the textile can be removed from its base, it may be machine-washed at a temperature no higher than 40°C.



Resistente al desgarro
Tear resistant



Fácil cuidado
Easy care



Resistente a los rayos UV
UV resistant



Resistente a la deformación
Deformation resistant



Resistente al moho
Mould resistant

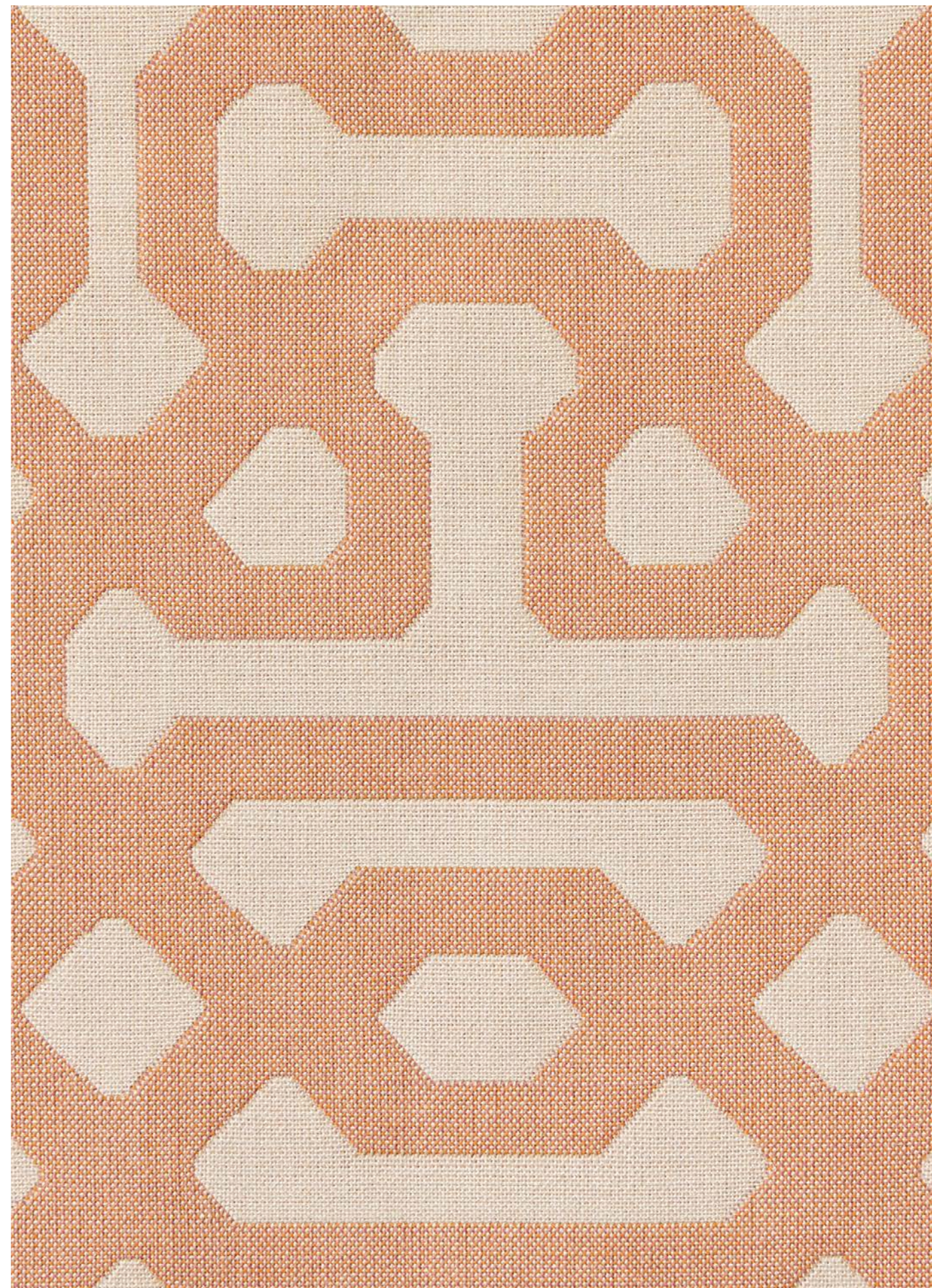

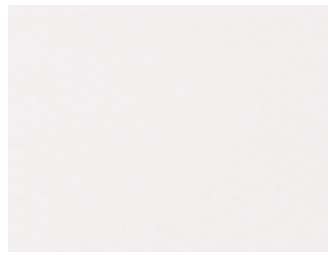

G1 22 [20000 C. Martindale]



G1 21 [20000 C. Martindale]



G1 1101 [20000 C. Martindale]



G1 1103 [20000 C. Martindale]



G1 1119 [20000 C. Martindale]



G1 1201 [20000 C. Martindale]



G2 1047 [25000 C. Martindale]

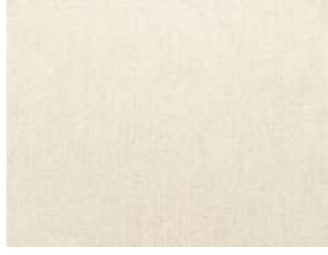

G2 1041 [25000 C. Martindale]



G2 1011 [25000 C. Martindale]



G2 1220 [35000 C. Martindale]



G2 1221 [35000 C. Martindale]
Disponible sólo en 2020
Only available in 2020



G2 1069 [25000 C. Martindale]



G2 1070 [25000 C. Martindale]



G2 1072 [25000 C. Martindale]

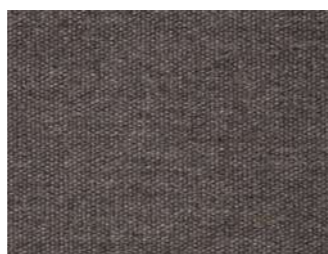

G2 1071 [25000 C. Martindale]
Disponible sólo en 2020
Only available in 2020



G2 1202 [25000 C. Martindale]

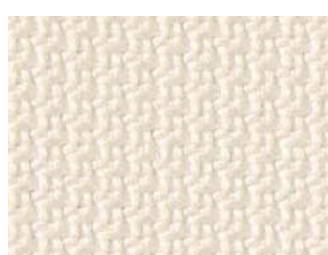

G3 1080 [80000 C. Martindale]

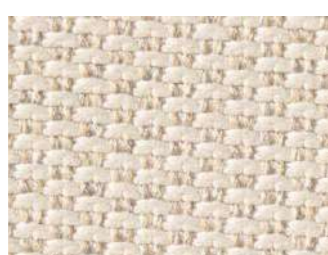

G3 1081 [80000 C. Martindale]



G3 1238 [80000 C. Martindale]



G3 1239 [80000 C. Martindale]



G3 1240 [80000 C. Martindale]



G3 1246 [22000 C. Martindale]



G3 1232 [50000 C. Martindale]



G3 1233 [50000 C. Martindale]

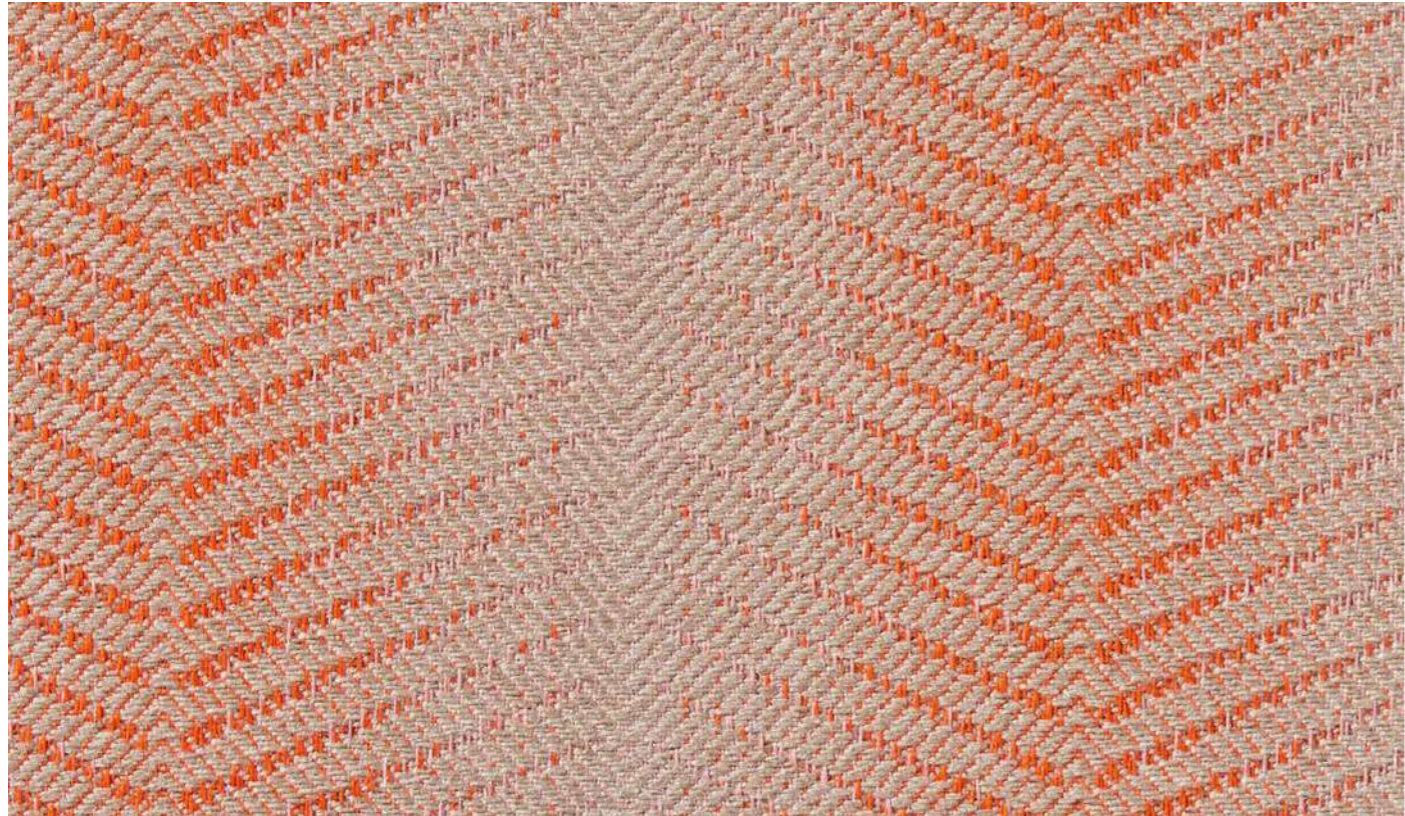

G2 1224 [80000 C. Martindale]

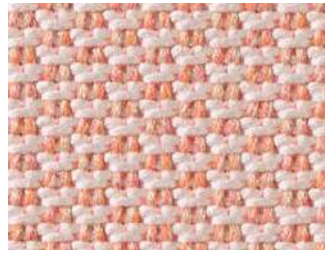

G3 1243 [80000 C. Martindale]
Disponible sólo en 2020
Only available in 2020



G2 1214 [25000 C. Martindale]



G2 1213 [25000 C. Martindale]

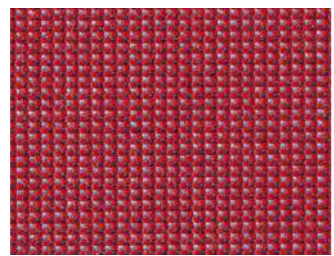

G2 1218 [15000 C. Martindale]
Disponible sólo en 2020
Only available in 2020



G2 1212 [25000 C. Martindale]



G2 1219 [25000 C. Martindale]
Disponible sólo en 2020
Only available in 2020

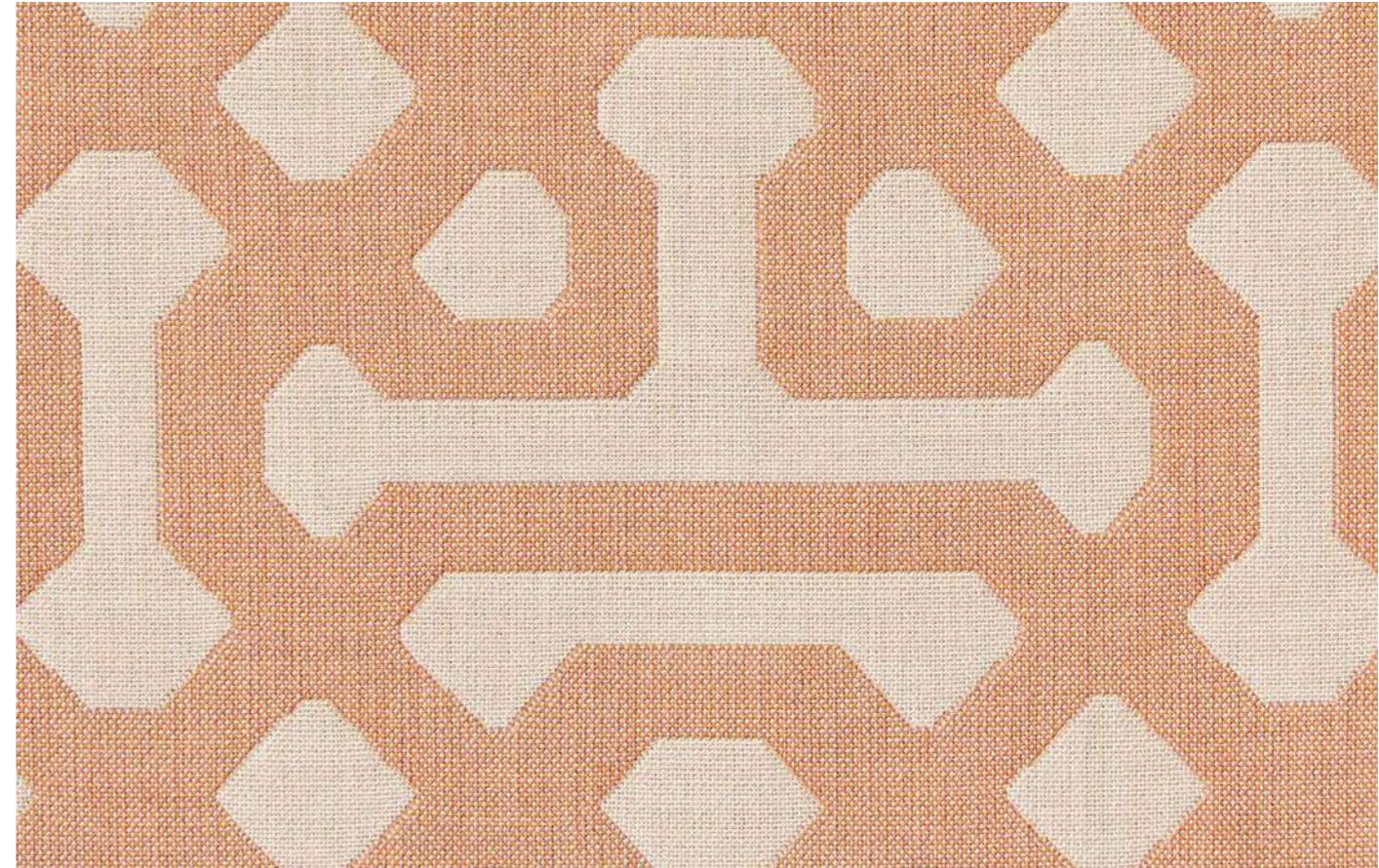

G3 1235 [50000 C. Wyzenbeek]

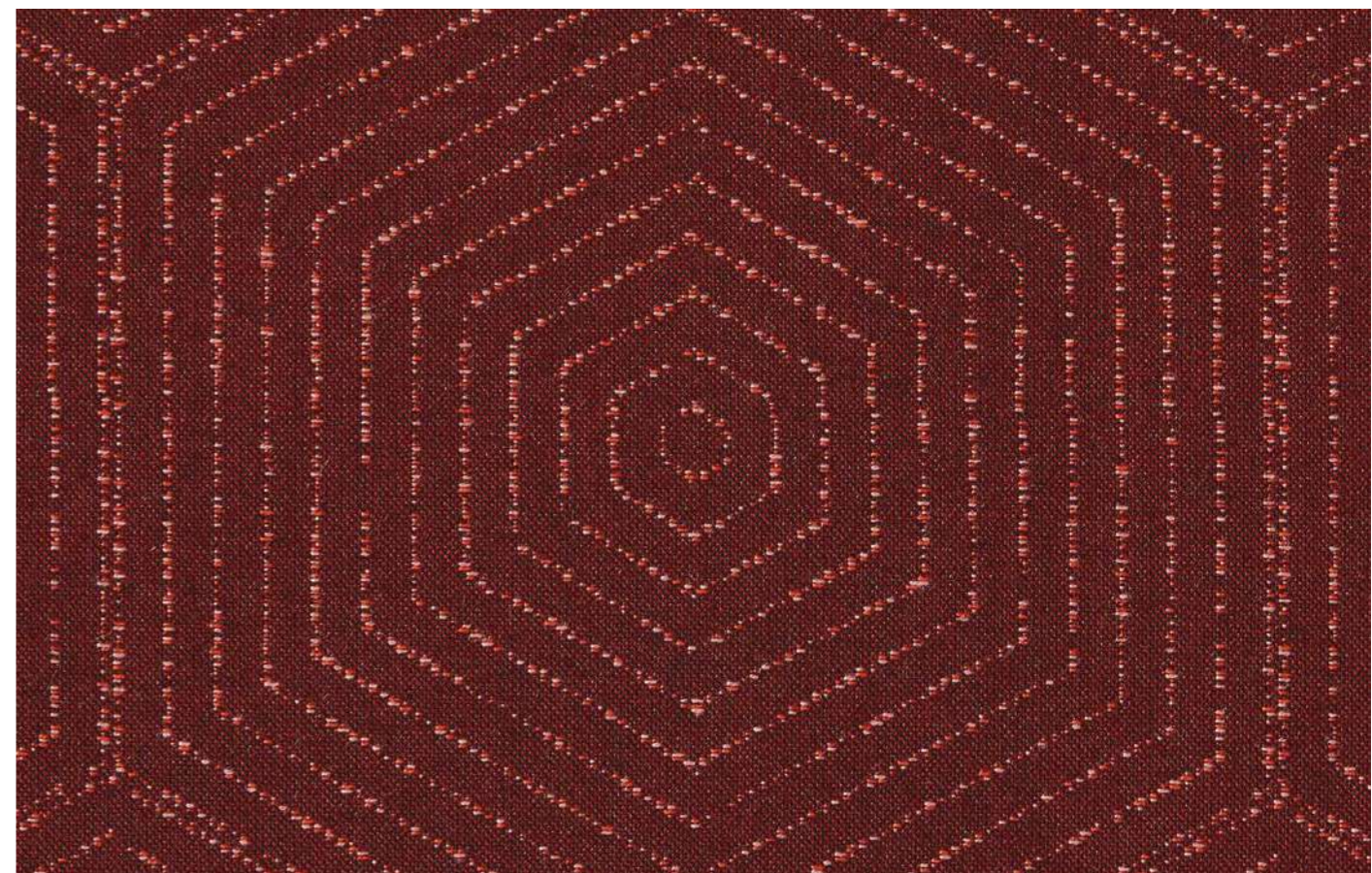

G3 1230 [100000 C. Wyzenbeek]

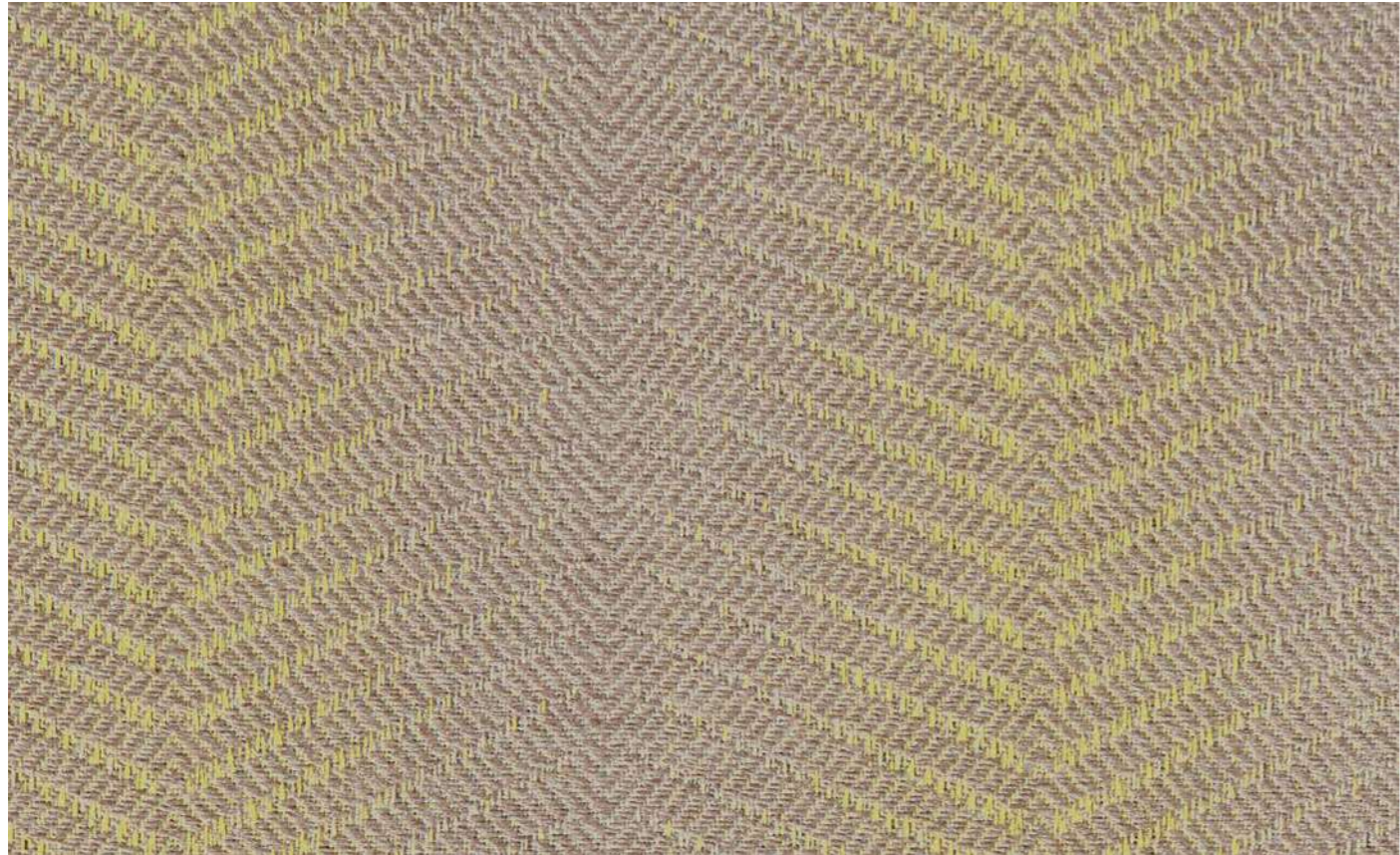

G2 1226 [80000 C. Wyzenbeek]

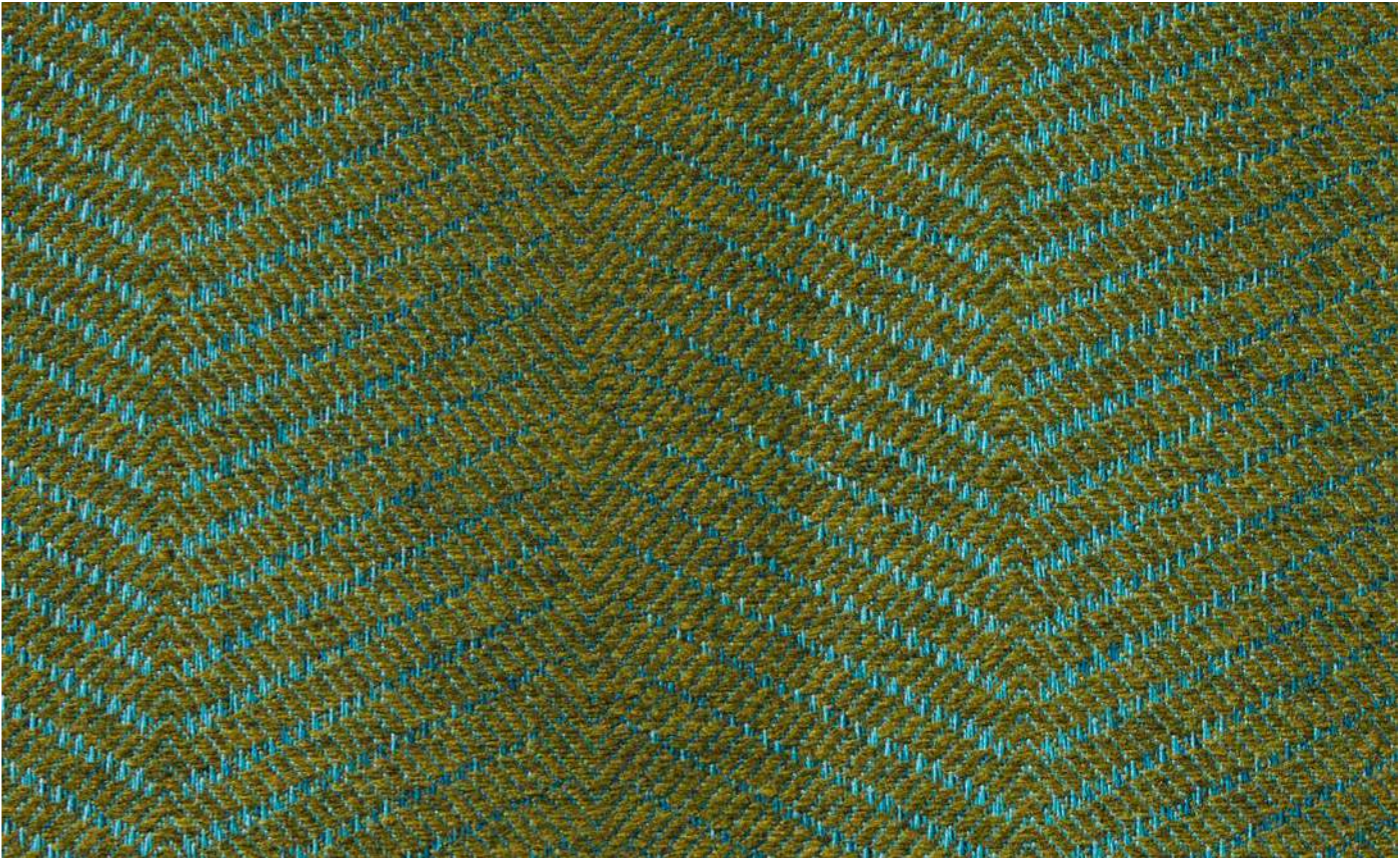

G2 1225 [80000 C. Wyzenbeek]



G3 1241 [80000 C. Martindale]
Disponible sólo en 2020
Only available in 2020



G2 1211 [25000 C. Martindale]
Disponible sólo en 2020
Only available in 2020



G2 1210 [25000 C. Martindale]
Disponible sólo en 2020
Only available in 2020

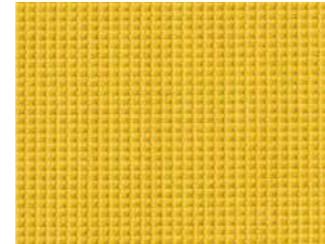

G2 1217 [15000 C. Martindale]
Disponible sólo en 2020
Only available in 2020



G3 1227 [46000 C. Martindale]



G3 1082 [80000 C. Martindale]
Disponible sólo en 2020
Only available in 2020



G2 1209 [25000 C. Martindale]



G2 1208 [25000 C. Martindale]
Disponible sólo en 2020
Only available in 2020

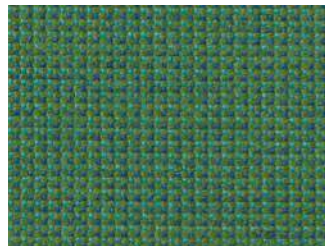

G2 1216 [15000 C. Martindale]
Disponible sólo en 2020
Only available in 2020



G3 1228 [46000 C. Martindale]

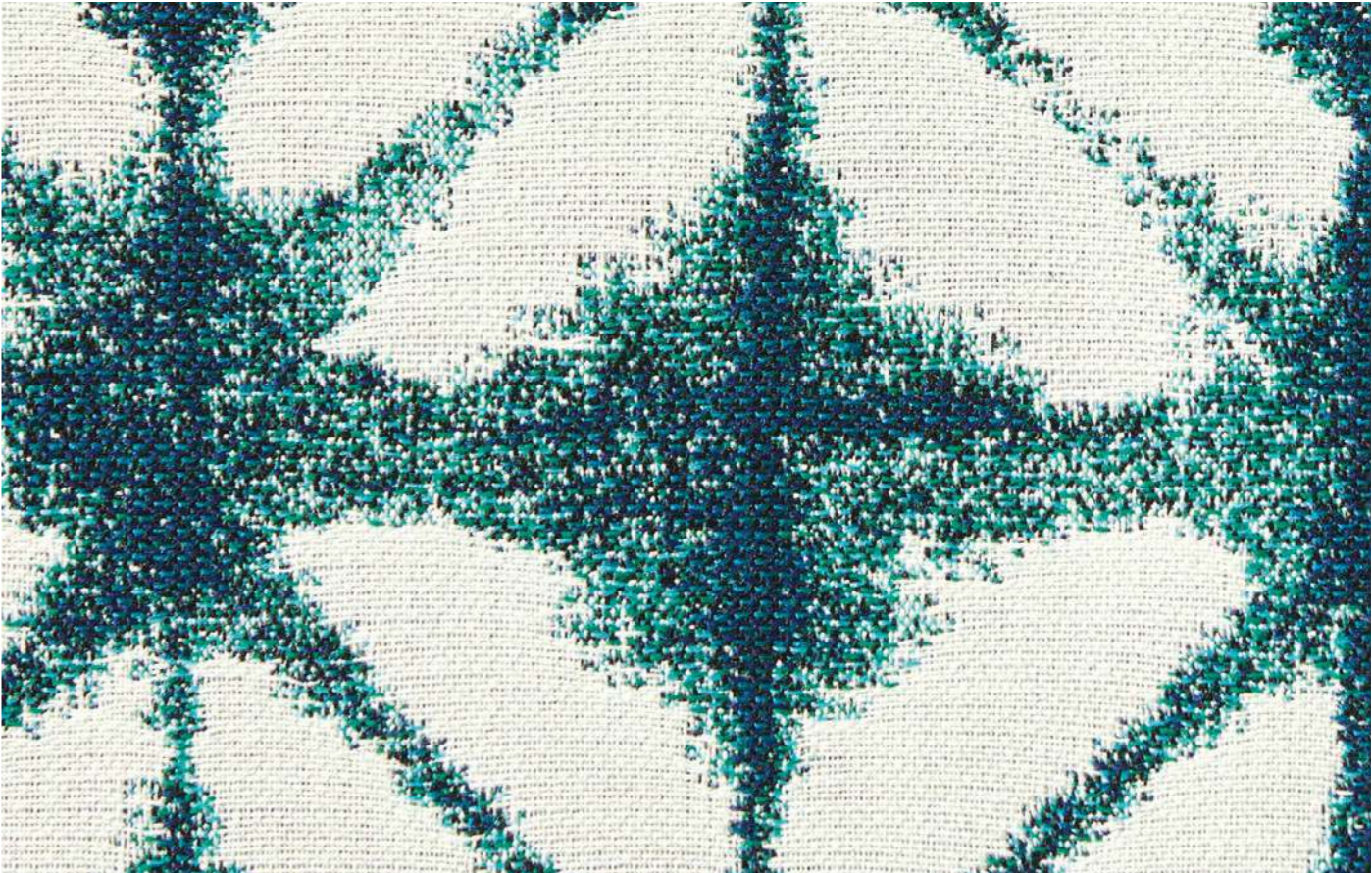

G3 1245 [22000 C. Wyzenbeek]

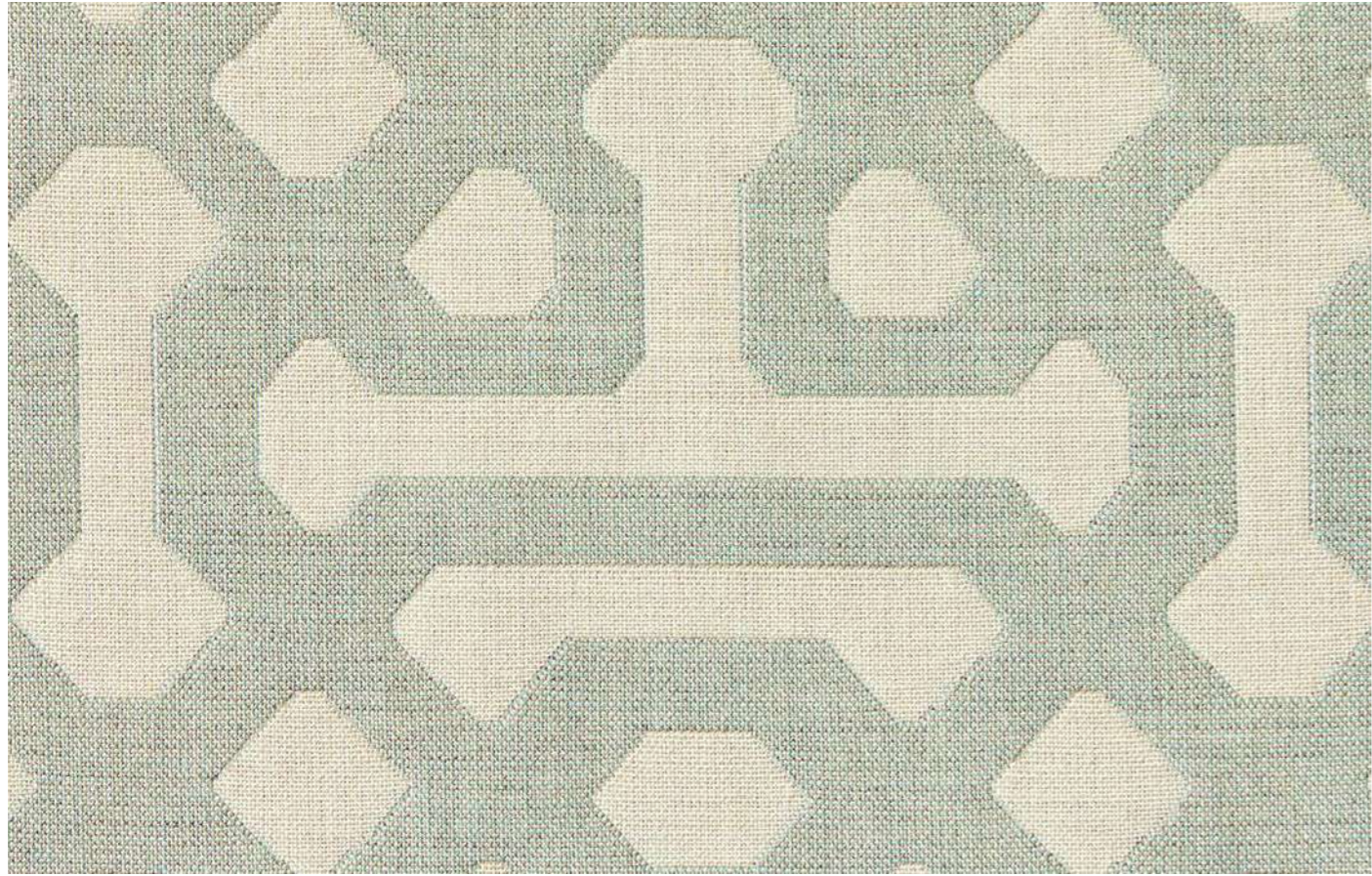

G3 1234 [50000 C. Wyzenbeek]

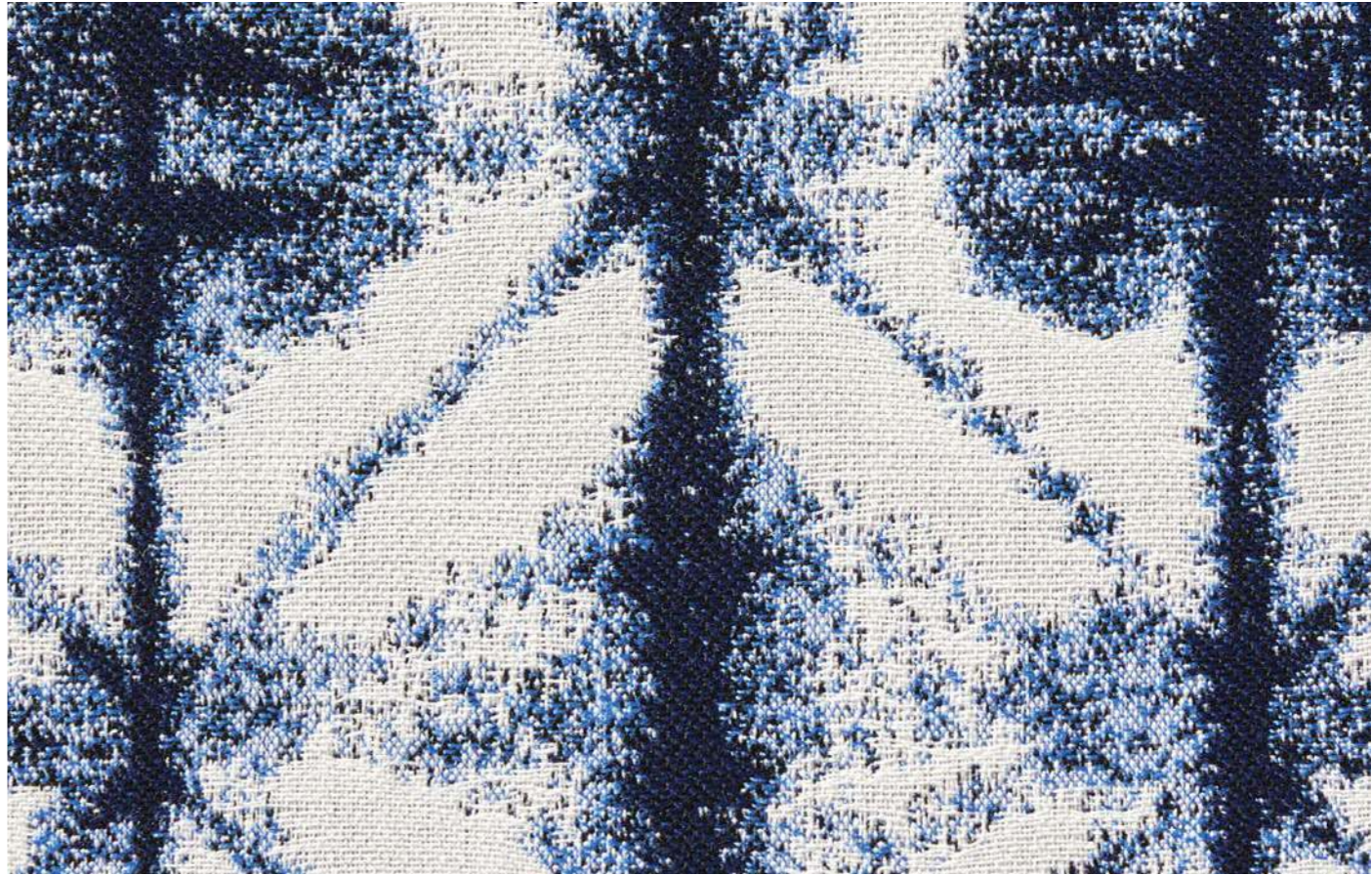

G3 1247 [22000 C. Wyzenbeek]



G3 1084 [80000 C. Martindale]
Disponible sólo en 2020
Only available in 2020

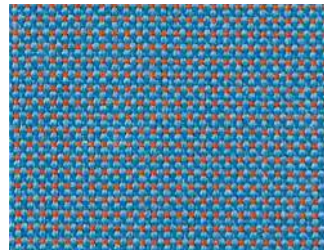

G2 1215 [15000 C. Martindale]
Disponible sólo en 2020
Only available in 2020



G2 1206 [25000 C. Martindale]



G2 1205 [25000 C. Martindale]



G3 1229 [46000 C. Martindale]



G2 1207 [25000 C. Martindale]



G2 1204 [25000 C. Martindale]



G2 1203 [25000 C. Martindale]
Disponible sólo en 2020
Only available in 2020



G3 1231 [100000 C. Wyzenbeek]

BATYLINE



G2 35 [120000 C. Martindale]

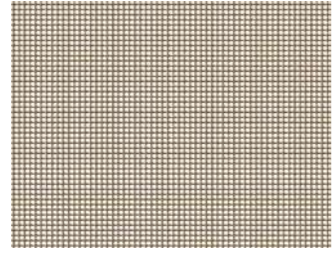

G2 37 [120000 C. Martindale]

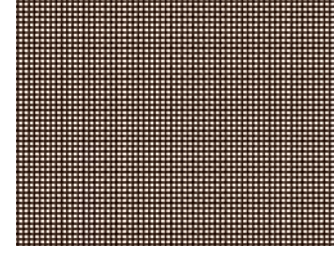

G2 38 [120000 C. Martindale]

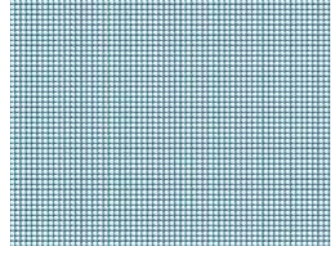

G2 39 [120000 C. Martindale]

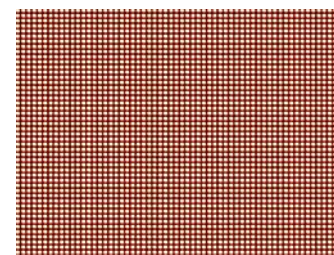

G2 40 [120000 C. Martindale]

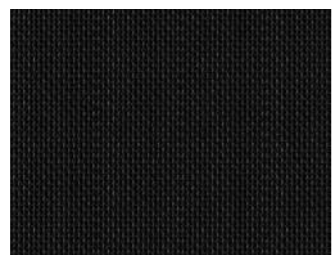

G2 57 [120000 C. Martindale]

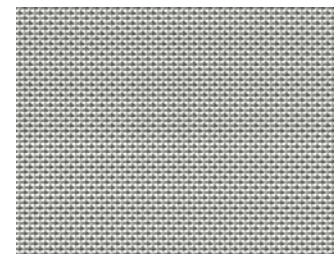

G3 13 [120000 C. Martindale]



G3 09 [120000 C. Martindale]

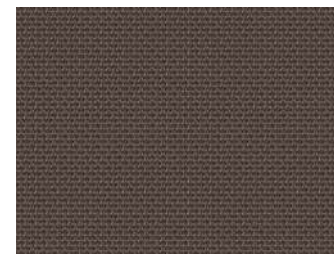

G3 10 [120000 C. Martindale]



G3 11 [120000 C. Martindale]

Photography
Ángel Segura

Art Direction
Perez Ochando

Photography Art Direction
Perez Ochando & POINT

Layout & Texts
POINT

POINT
Partida Planet, s/n.
03727 Xaló (Alicante) Spain
T. +34 966 480 132
info@point1920.com
www.point1920.com