

CLAIR — LIZZIE — WENDY

Un omaggio al potere seduttivo del design. Un'ispirazione dal gusto lievemente retrò, eco di tendenze anni '60-'70 rivisitate in chiave contemporanea.

Clair, Lizzie e Wendy sono così. Linee che catturano lo sguardo e imbottiture che inducono a sedersi. Irriverenti piedini conici in quattro finiture e colori vivaci nella veste in velluto – solo una delle infinite interpretazioni possibili grazie all'ampia gamma di tessuti Felis. Tre nuove poltroncine, con divanetti e pouf abbinati, in grado di prendersi la scena e allo stesso tempo di sentirsi a loro agio in ogni tipo di ambiente. In un living, in una zona notte o, perché no, nella hall di un albergo e in un locale: ovunque si scelga di dar voce, insieme al comfort, allo stile.

A tribute to the power of design to seduce. Inspiration with a slightly retro taste, an echo of '60s and '70s trends revisited with a contemporary twist. These are Clair, Lizzie and Wendy. Eye-catching design and padding invite you to come and sit down. Irreverent conical feet in four finishes and brightly coloured velvet covers – just one of the endless interpretations made possible by the wide range of Felis fabrics.

Three new armchairs with matching sofas and poufs able to steal the show whilst feeling at ease in any type of environment. In a living room, sleeping area or why not, in the hall of a hotel or nightclub: wherever style and comfort are expressed together.

Un tribut au pouvoir séducteur du design. Une inspiration au goût légèrement rétro, écho de tendances des années 60-70 revues en clef contemporaine.

Clair, Lizzie et Wendy sont ainsi. Aux lignes qui capturent le regard et aux rembourrages qui incitent à s'asseoir. Des petits pieds coniques irrespectueux en quatre finitions et les couleurs vives du tissu en velours – il s'agit d'une des interprétations possibles infinies grâce à la vaste gamme des tissus Felis.

Trois nouveaux petits fauteuils, avec des petits canapés et des poufs assortis, capables de capturer la scène et en même temps de se sentir à leur aise en quelconque type de milieu. Dans un salon, dans une zone nuit ou, pourquoi pas, dans une entrée d'un hôtel et d'un club: où que vous choisissiez vouloir exprimer, en y ajoutant le confort, le style.

Un homenaje al poder de seducción del diseño. Una inspiración con un sabor ligeramente retro, un eco de las tendencias de los años 60 y 70 revisadas en clave contemporánea.

Clair, Lizzie y Wendy son así. Líneas que capturan las miradas y acolchados que inducen a sentarse. Patas cónicas irreverentes en cuatro acabados y colores llamativos que evocan el terciopelo, sólo una de las infinitas interpretaciones posibles gracias a la amplia gama de tejidos Felis.

Tres nuevos sillones, con sofás y pufs a juego, capaces de protagonizar y, al mismo tiempo, sentirse a gusto en cualquier tipo de ambiente. En una sala de estar, en una zona de descanso o, por qué no, en el vestíbulo de un hotel o un local: dondequiera que se decida dar voz al estilo, junto con el confort.





LIZZIE

P. 12



P. 4

CLAIR



P. 18

WENDY

CLAIR



La forma arrotondata dello schienale incontra le linee più squadrate dei braccioli. Clair è il luogo ideale per abbandonarsi al relax, magari immersi in un buon libro, come suggeriscono gli ambienti dalla raffinata impronta *industrial* di queste pagine.

The rounded backrest meets the more square lines of the armrests. Clair is the ideal place to indulge in relaxation, perhaps immersed in a good book, as suggested by the refined *industrial* stamp of the rooms here.

La forme arrondie du dossier rencontre les lignes plus carrées des accoudoirs. Clair est le lieu idéal pour s'abandonner au relax, éventuellement immergé dans un bon livre, comme le suggèrent les milieux aux empreintes *industrial* raffinées de ces pages.

La forma redondeada del respaldo se une a las líneas más cuadradas de los apoyabrazos. Clair es el lugar ideal para relajarse, quizás en compañía de un buen libro, como sugiere el refinado estilo *industrial* de estas páginas.





CLAIR





CLAIR





CLAIR



LIZZIE



Una curva inattesa spezza la prevedibilità delle geometrie. In quel capriccio del bracciolo emerge con forza l'identità visiva di Lizzie, equilibrata ribellione delle forme che sdrammatizza con classe anche la formalità di un ambiente classico moderno.

An unexpected curve breaks up the predictability of the geometric shapes. Lizzie's visual identity emerges with all its force in the whim of the armrest, as shape rebels with restraint, tastefully playing down the formality of a modern classic environment.

Une courbe inattendue casse la prévisibilité des géométries. Dans ce caprice de l'accoudoir l'identité visuelle de Lizzie apparaît avec force, rébellion équilibrée des formes qui dédramatise avec classe également la formalité d'un milieu classique moderne.

Una curva inesperada rompe la previsibilidad de las geometrías. En ese capricho del apoyabrazos emerge con fuerza la identidad visual de Lizzie, una equilibrada rebelión de formas que minimiza con clase incluso la formalidad de un entorno clásico-moderno.





LIZZIE





LIZZIE



WENDY



L'imponenza dei braccioli racchiude in un abbraccio la morbida seduta. È impossibile resistere a Wendy e alla promessa di comfort custodita nelle linee armoniosamente rotonde del suo design, ideali per valorizzare anche le stanze più eleganti.

The grandeur of the armrests encloses the soft seating in an embrace. It's impossible to resist Wendy and the promise of comfort embodied in the harmoniously rounded design, the ideal way to embellish even the most elegant rooms.

La grandeur des accoudoirs renferme dans l'avant-bras une assise souple. Il est impossible de résister à Wendy et à la promesse de confort cachée dans les lignes harmonieuses arrondies de son design, idéales pour valoriser également les chambres les plus élégantes.

Los imponentes apoyabrazos abrazan el mullido asiento. Es imposible resistirse a Wendy y a la promesa de confort que encierran las líneas armoniosamente redondeadas de su diseño, ideales para realzar las habitaciones más elegantes.





WENDY



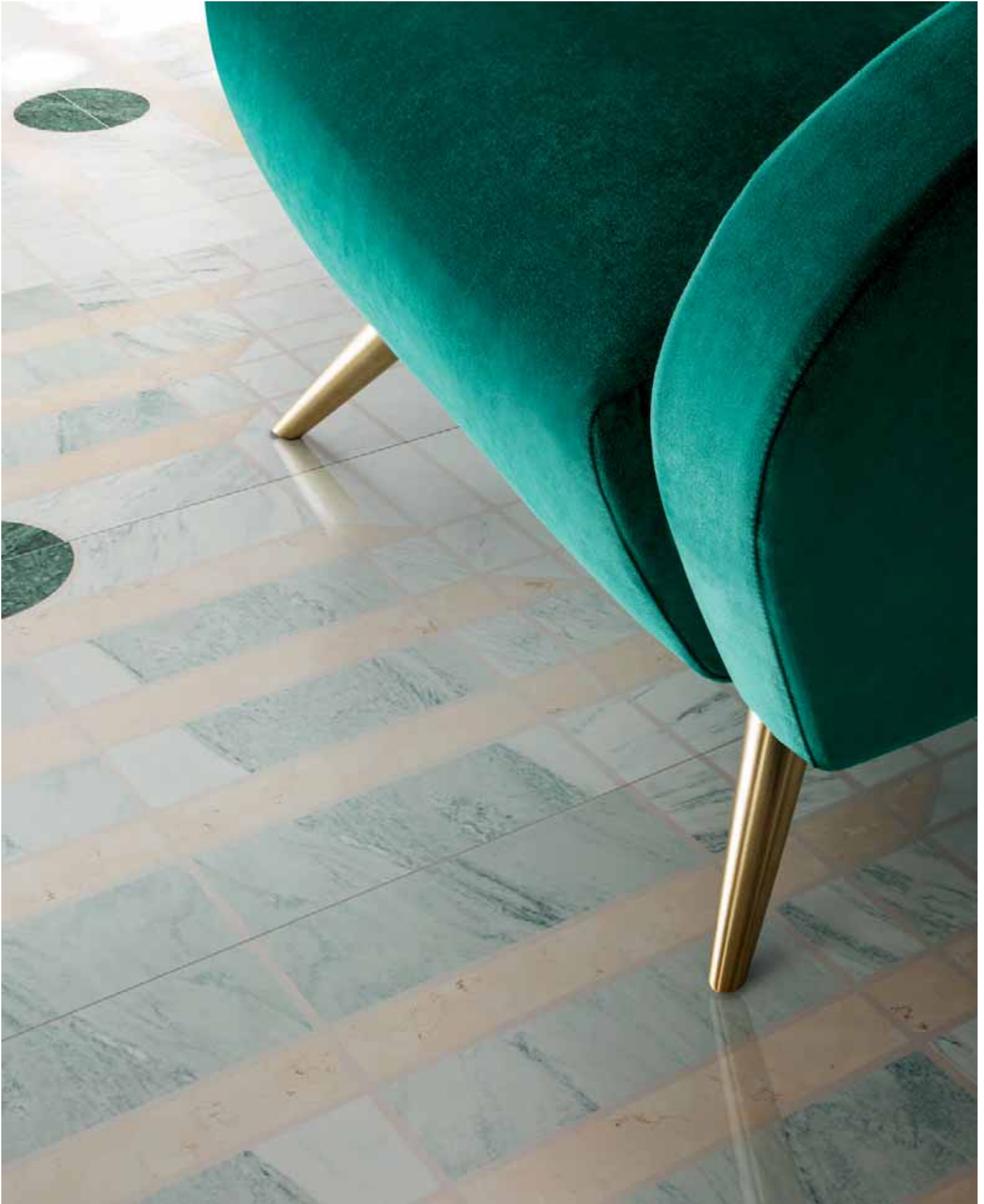

WENDY



CLAIR — LIZZIE — WENDY

TECHNICAL SECTION

I piedini dal design a cono rivolti verso l'esterno sono uno degli elementi più originali delle nuove poltroncine Felis. Con il loro tocco anticonformista, alleggeriscono e donano personalità alla struttura. Possono essere scelti in quattro finiture, per quattro diverse interpretazioni di stile.

The feet with their cone-shaped, outward-facing design are one of the most original elements of the new Felis armchairs. Their anti-conformist touch lightens up the structure, lending it personality. There are four finishes to choose from, for four different style interpretations.

Les petits pieds en forme de cône tournés vers l'extérieur sont un des éléments les plus originaux des nouveaux petits fauteuils Felis. Avec leur touche anticonformiste, ils allègent et offrent personnalité à la structure. Ils peuvent être choisis en quatre finitions, pour quatre interprétations de style différentes.

Las patas de diseño cónico están orientadas hacia el exterior y son uno de los elementos más originales de las nuevas butacas Felis. Con su toque anticonformista, aligeran y dan personalidad a la estructura. Pueden elegirse en cuatro acabados, para cuatro interpretaciones de estilo diferentes.



CROMO
CHROME
CHROME
CROMO



RAME
COPPER
CUIVRE
COBRE



OTTONE
BRASS
LAITON
LATÓN



BRONZO
BRONZE
BRONZE
BRONCE

MONTAGGIO DEI PIEDINI

ASSEMBLING THE FEET

MONTAGE DES PETITS PIEDS

MONTAJE DE LAS PATAS

SCHEMA PER L'ASSEMBLAGGIO

Insieme ai modelli Clair, Lizzie e Wendy viene consegnato un kit completo per il montaggio dei piedini. L'operazione è semplicissima, adatta anche ai meno esperti.

Il kit contiene:

- 4 piedi a sbalzo dotati di gommino antiscivolo;
- 16 viti a testa piatta;
- chiave a brugola;
- istruzioni di montaggio.

ASSEMBLY DIAGRAM

The Clair, Lizzie and Wendy models come with a complete kit for assembling the feet. The operation is extremely simple and suitable for people with no previous experience.

The kit contains:

- 4 cantilevered feet fitted with non-slip rubber pads;
- 16 flat-head screws;
- Allen key;
- assembly instructions.

SCHÉMA POUR L'ASSEMBLAGE

Un kit complet est fourni avec les modèles Clair, Lizzie et Wendy pour le montage des petits pieds. L'opération est très simple, adaptée même aux moins experts.

Le kit comprend:

- 4 pieds à surplomb équipés de caoutchouc antidérapant;
- 16 vis à tête plate;
- clef Allen;
- instructions de montage.

ESQUEMA DE MONTAJE

Los modelos Clair, Lizzie y Wendy se entregan junto con un kit completo para el montaje de las patas. La operación es muy sencilla y puede ser realizada también por las personas menos expertas.

El kit contiene:

- 4 patas en voladizo equipadas con terminal antideslizante;
- 16 tornillos de cabeza plana;
- llave Allen;
- instrucciones de montaje.

Step 01

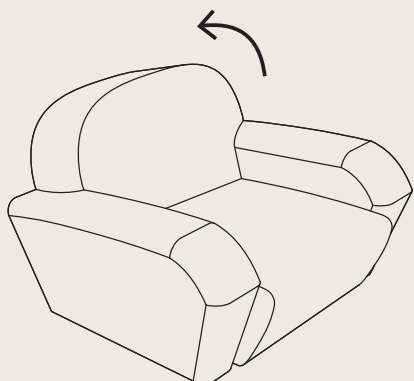

Step 02

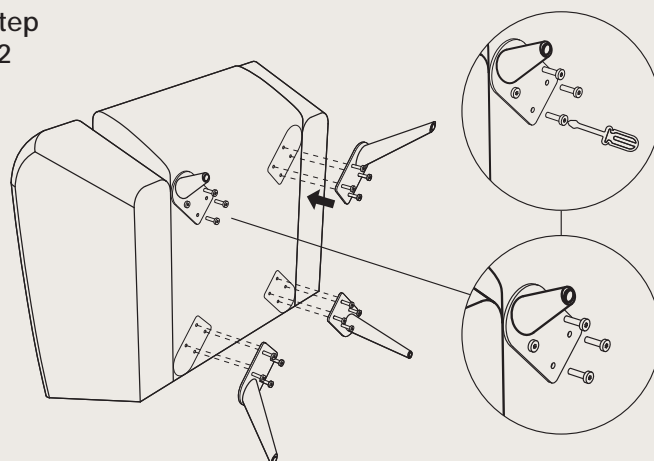

Step 03

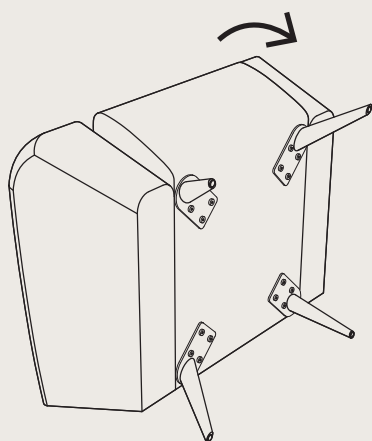

Step 04

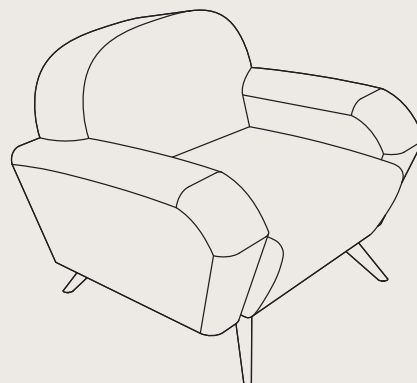

COMPLETAMENTE SFODERABILI

COMPLETELY REMOVABLE COVERS

ENTIÈREMENT DÉHOUSSABLE

COMPLETAMENTE DESENFUNDABLES

PRATICITÀ E VELOCITÀ

I rivestimenti sono sfoderabili al 100% per consentire una facile pulizia e manutenzione. I braccioli possono essere sganciati in modo semplice e sicuro.

PRACTICALITY AND SPEED

Covers are 100% removable for ease of cleaning and maintenance. Armrests can be dismantled simply and safely.

PRACTICITÉ ET VITESSE

Les revêtements sont 100% déhoussables afin de permettre un nettoyage et une manutention faciles. Les accoudoirs peuvent se décrocher facilement et en sécurité.

PRACTICIDAD Y VELOCIDAD

Los tapizados son desenfundables al 100% para facilitar la limpieza y el mantenimiento. Los apoyabrazos se pueden desenganchar de forma fácil y segura.

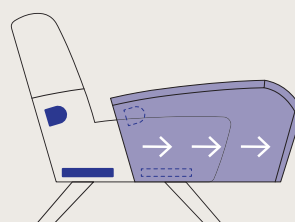
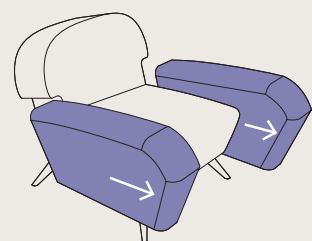
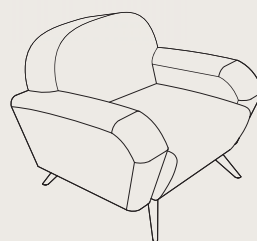

SMONTAGGIO BRACCIOLI
DISMANTLING ARMRESTS
DÉMONTAGE ACCOUDOIRS
DESMONTAJE DE LOS
APOYABRAZOS

CLAIR — LIZZIE — WENDY

TECHNICAL SECTION

STRUTTURA

Realizzata con masselli portanti in legno di abete massiccio di vari spessori. Parti di tamponamento in fibra grezza e/o compensato. Telaio in multistrato da 18mm. Fibra grezza e agglomerato di legno in classe E1, pertanto a bassa emissione di formaldeide. I braccioli sono ancorati alla base con baionette. Il telaio è completamente rivestito con resinato da 200g accoppiato a maglina di 100% poliestere.

FRAME

Load-bearing parts made of solid fir in various thicknesses. Reinforcement parts in wood fibre and/or plywood. 18mm multi-layered wooden frame. Low formaldehyde emissions wood fibre and particleboard (Class E1). The armrests are anchored to the base by means of bayonet fittings. The frame is completely covered with 200g resin wadding bonded to 100% polyester jersey.

STRUCTURE

Réalisée avec des loupes portantes en bois de pin massif de différentes épaisseurs. Parties de remplissage en fibre brute et/ou compensé. Châssis contreplaqué de 18mm. Fibre brute et aggloméré de bois en classe E1, donc à basse émission de formaldéhyde. Les accoudoirs sont ancrés à la base par des baïonnettes. Le châssis est complètement revêtu par 200 g de résiné accouplé à une maille 100% polyester.

ESTRUCTURA

Realizada con madera maciza portante de abeto de distintos espesores. Piezas de remate en fibra bruta y/o madera contrachapada. Armazón de estratificado de 18mm. La fibra bruta y la madera aglomerada pertenecen a la clase E1, es decir con baja emisión de formaldehído. Los apoyabrazos se fijan a la base con sistema de bayoneta. El armazón está completamente recubierto de material resinado de 200g combinado con jersey 100% poliéster.

MOLLEGGIO

Realizzato in nastri da 80mm tesi meccanicamente, composti da fili di nylon avvolti a spirale.

SPRINGING

Made of 80mm wide mechanically tensioned webbing composed of spirally wound nylon strands.

RESSORT

Réalisé en bandes de 80mm tirés mécaniquement, composés par des fils de nylon enroulés en spirale.

SISTEMA DE SUSPENSIÓN

Realizado con cinchas de 80mm, tensadas mecánicamente, compuestas por hilos de nylon envueltas en forma de espiral.

IMBOTTITURA

Tamponi braccioli D25, D30, D40. Seduta D30 HS. Schiena D18 morbido.

PADDING

Armrest reinforcement pads D25, D30, D40. Seat D30 HS. Back D18 soft.

REMBOURRAGE

Remplissages des accoudoirs D25, D30, D40. Assise D30 HS. Dossier D18 souple.

RELLENO

Acolchado de los apoyabrazos D25, D30 y D40. Asiento D30 HS. Respaldo D18 mullido.

PIEDI

Piede in metallo verniciato con polveri epossidiche e dotato di gommino antiscivolo.

FEET

Epoxy powder coated metal feet fitted with non-slip rubber pads.

PIEDS

Pied en métal vernis en poudre époxyde et équipé de caoutchouc antidérapant.

PATAS

Patatas de metal pintado con polvo epoxy y equipado con terminal antideslizante.

CLAIR



Art. / Item
Art. / Art. **01**

Poltrona

Armchair
Fauteuil
Sillon

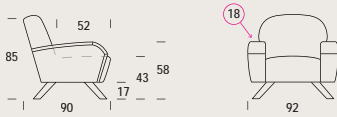

Mt. tessuto / Fabric l.m. / Métrage Base / M. base 4.5
Volume mc / Volume m³ / Volume m³ / Volumen m³ 0.8

Art. / Item
Art. / Art. **02**

Divano

Sofa
Canapé
Sofa

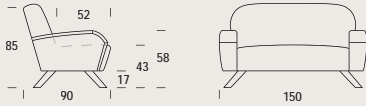

Mt. tessuto / Fabric l.m. / Métrage Base / M. base 6
Volume mc / Volume m³ / Volume m³ / Volumen m³ 1.4

Art. / Item
Art. / Art. **10**

Pouf

Pouf
Pouf
Pouf

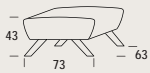

Mt. tessuto / Fabric l.m. / Métrage Base / M. base 2
Volume mc / Volume m³ / Volume m³ / Volumen m³ 0.3

Piedini disponibili nelle finiture / Feet available in finishes / Petits pieds disponibles dans les finitions / Patas disponibles en los acabados:



CROMO
CHROME
CHROME
CROMO



RAME
COPPER
CUIVRE
COBRE



OTTONE
BRASS
LAITON
LATÓN



BRONZO
BRONZE
BRONZE
BRONCE

LIZZIE



Art. / Item
Art. / Art. **01**

Poltrona

Armchair
Fauteuil
Sillon

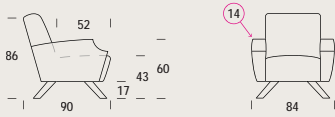

Mt. tessuto / Fabric Lm. / Métrage Base / M. base 4.5
Volume mc / Volume m³ / Volume m³ / Volumen m³ 0.8

Art. / Item
Art. / Art. **02**

Divano

Sofa
Canapé
Sofa

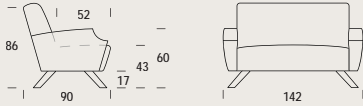

Mt. tessuto / Fabric Lm. / Métrage Base / M. base 6
Volume mc / Volume m³ / Volume m³ / Volumen m³ 1.4

Art. / Item
Art. / Art. **10**

Pouf

Pouf
Pouf
Pouf

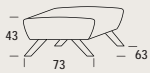

Mt. tessuto / Fabric Lm. / Métrage Base / M. base 2
Volume mc / Volume m³ / Volume m³ / Volumen m³ 0.3

Piedini disponibili nelle finiture / Feet available in finishes / Petits pieds disponibles dans les finitions / Patas disponibles en los acabados:



CROMO
CHROME
CHROME
CROMO



RAME
COPPER
CUIVRE
COBRE



OTTONE
BRASS
LAITON
LATÓN



BRONZO
BRONZE
BRONZE
BRONCE

WENDY



Art. / Item
Art. / Art. **01**

Poltrona

Armchair
Fauteuil
Sillon

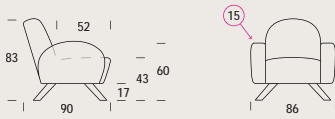

Mt. tessuto / Fabric l.m. / Métrage Base / M. base 4.5
Volume mc / Volume m³ / Volume m³ / Volumen m³ 0.8

Art. / Item
Art. / Art. **02**

Divano

Sofa
Canapé
Sofa

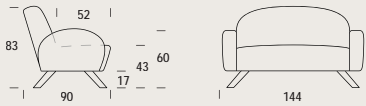

Mt. tessuto / Fabric l.m. / Métrage Base / M. base 6
Volume mc / Volume m³ / Volume m³ / Volumen m³ 1.4

Art. / Item
Art. / Art. **10**

Pouf

Pouf
Pouf
Pouf

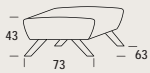

Mt. tessuto / Fabric l.m. / Métrage Base / M. base 2
Volume mc / Volume m³ / Volume m³ / Volumen m³ 0.3

Piedini disponibili nelle finiture / Feet available in finishes / Petits pieds disponibles dans les finitions / Patas disponibles en los acabados:



CROMO
CHROME
CHROME
CROMO



RAME
COPPER
CUIVRE
COBRE



OTTONE
BRASS
LAITON
LATÓN



BRONZO
BRONZE
BRONZE
BRONCE



felis
SOFT LIVING

FELIS SRL UNIPERSONALE

Via P. Zorutti, 22
33074 Fontanafredda (PN) Italy

tel. +39 0434 737052
fax +39 0434 737024

info@felis.it

www.felis.it

Seguici su



art direction
Gianluca Marcon

research and design
Fells Lab

graphic design
creativeblend.it

copywriting
foongo.com

photos - visualization
Photografica
Lonestudio

styling
Federica Baro

print
XXX

thanks to:
Medulum
Del Savio Marmi